

Inclinometers

**For dynamic applications
1- and 2-axis measurement**

IN51

Analog



Fast measurement results with high accuracy.

Sensor fusion consisting of an acceleration and rotation rate measuring cells (gyroscope) minimizes the effects of vibrations and interference accelerations.

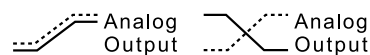

**Order code
1-axis**

8.IN51.1XXX.11X
Type a b c d

- a Measuring range**
7 = 0° ... 360° (±180°)
8 = 0° ... 180° (±90°)



- b Analog interface**
1 = 4 ... 20 mA
2 = 0,1 ... 4,9 V
3 = 0,5 ... 4,5 V
4 = 0 ... 5 V
5 = 0 ... 10 V
- c Filter**
S = slow
M = medium
F = fast (recommendation)
V = very fast

- d Type of connection**
1 = M12 connector, 8-pin
2 = M12 connector, 5-pin
4 = cable 5-core, 1 m
B = cable 5-core, special lengths

Stock types
8.IN51.171F.112

**Order code
2-axis**

8.IN51.2XXX.11X
Type a b c d

- a Measuring range**
1 = ±10°
2 = ±15°
3 = ±30°
4 = ±45°
5 = ±60°
6 = ±85°



- b Analog interface**
1 = 4 ... 20 mA
2 = 0,1 ... 4,9 V
3 = 0,5 ... 4,5 V
4 = 0 ... 5 V
5 = 0 ... 10 V
- c Filter**
S = slow
M = medium
F = fast (recommendation)
V = very fast

- d Type of connection**
1 = M12 connector, 8-pin
2 = M12 connector, 5-pin
4 = cable 5-core, 1 m
B = cable 5-core, special lengths

Stock types
8.IN51.261F.112
8.IN51.241F.112

Accessories

Order no.

Teach adapter

Teach adapter, 5-pin
Teach adapter, 8-pin

05.TX40.1
8.0010.9000.0017

EMC shield terminal

shield diameter 3.0 ... 12.0 mm

8.0000.4G06.0312

Cables and connectors

Order no.

Preassembled cables

M12 female connector with coupling nut, 5-pin, A coded, straight single ended
2 m [6.56'] PVC cable

M12 female connector with coupling nut, 8-pin, A coded, straight single ended
2 m [6.56'] PVC cable

05.00.6081.2211.002M
05.00.6041.8211.005M

Connectors

M12 female connector with coupling nut, 8-pin, A coded, straight (metal)
M12 female connector with coupling nut, 5-pin, A coded, straight (metal)

05.CMB 8181-0
8.0000.5116.0000

Further Kübler accessories can be found at: kuebler.com/accessories
Further Kübler cables and connectors can be found at: kuebler.com/connection-technology

Inclinometers

**For dynamic applications
1- and 2-axis measurement**

IN51

Analog

Technical data

General data 1-axis measurement

Measuring range	0 ... 360°
Resolution	current interface 0.01° internal sensor 12 bit D/A converter voltage interface 12 bit
Repeat accuracy	≤ 0.1°
Linearity deviation	≤ ±0.3°
Temperature drift	≤ ±0.005 %/K
Accuracy (at 25°C)	±0.1 ... ±0.3° depending on the measuring range

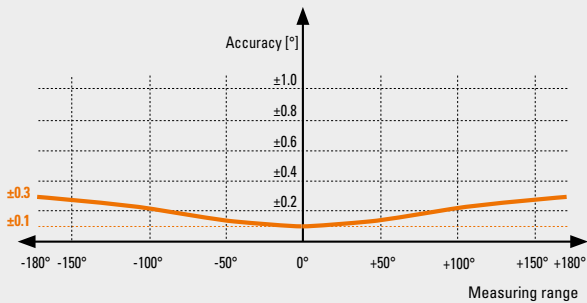

Course of the output signal – factory setting

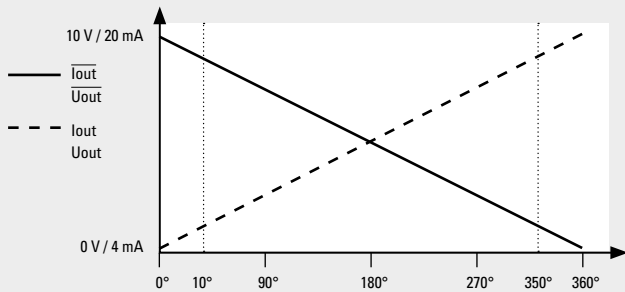

General data 2-axis measurement

Measuring range	-85° ... +85°
Resolution	current interface 0.01° internal sensor 12 bit D/A converter voltage interface 12 bit
Repeat accuracy	≤ 0.1°
Linearity deviation	≤ ±0.2°
Temperature drift	≤ ±0.005 %/K
Accuracy (at 25°C)	≤ ±0.1 ... ±0.7° depending on the measuring range

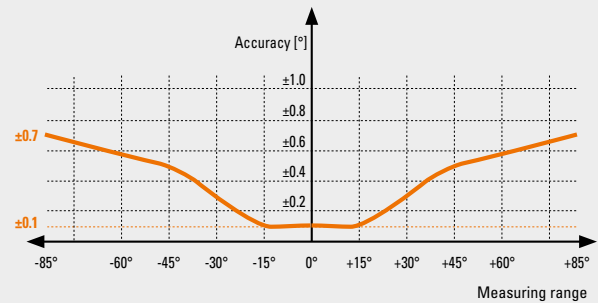

Course of the output signal – factory setting

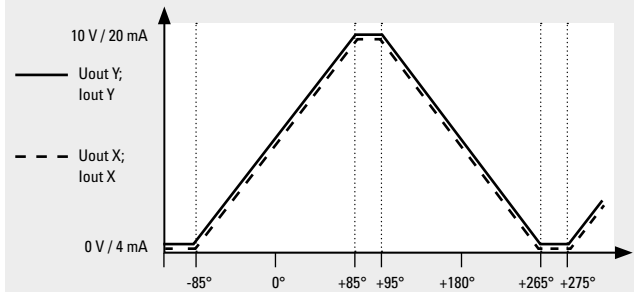

Inclinometers

For dynamic applications 1- and 2-axis measurement

IN51

Analog

Electrical characteristics current interface

Supply voltage	4 ... 20 mA	10 ... 30 V DC
Current consumption	max. 40 mA	
Reverse polarity protection of the supply voltage	yes	
PowerON Time (PowerOn until valid output value)	< 0.5 s	
Output load	at 10 VDC at 24 VDC at 30 VDC	max. 200 Ohm max. 900 Ohm max. 1200 Ohm
Setting time	< 1 ms ($R_{load} = 900 \text{ Ohm}$, 25 °C)	
Sampling rate	500 Hz (20 ms)	
Limit frequency with Butterworth filter	1 ... 20 Hz, 8th order	

Mechanical characteristics

Electrical connection	M12 connector, 8-pin M12 connector, 5-pin cable, 5-pin	
Weight	approx. 60 g [2.1 oz]	
Protection acc. to EN 60529	IP68/IP69k	
Working temperature range	-40 °C ... +85 °C [-40 °F ... +185 °F]	
Material	housing	plastic, PC
Shock resistance acc. to EN 60068-2-27	100 m/s ² , 10 ... 2000 Hz	
Vibration resistance acc. to EN 60068-2-6	1000 m/s ² , 6 ms	
Dimensions	44.5 x 42.5 x 20 mm [1.75 x 1.67 x 0.79"]	

Electrical characteristics voltage interface

Supply voltage	0,1 ... 4,9 V / 0,5 ... 4,5 V / 0 ... 5 V	10 ... 30 V 15 ... 30 V
Current consumption	max. 40 mA	
Reverse polarity protection of the supply voltage	yes	
PowerON Time (PowerOn until valid output value)	< 0.5 s	
Output load	max. 10 mA	
Setting time	< 1 ms ($R_{load} = 1000 \text{ Ohm}$, 25 °C)	
Sampling rate	500 Hz (20 ms)	
Limit frequency with Butterworth filter	1 ... 20 Hz, 8th order	

EMC

Relevant standards	EN 61326-1	Electrical equipment for measurement, control and laboratory use
	EN 55011 Klasse B, EN 61000-6-3	Emitted interferences for residential environments

Approvals

UL compliant in accordance with	File no. E224618	
CE compliant in accordance with	EMC Directive	2014/30/EU
	RoHS Directive	2011/65/EU

Inclinometers

**For dynamic applications
1- and 2-axis measurement**

IN51

Analog

Terminal assignment, 1-axis

Type of connection	M12 connector, 8-pin									
1	Signal – Interface 1 (current):	0 V	+V	Iout+	Iout-	$\overline{\text{Iout+}}$	$\overline{\text{Iout-}}$	Teach 1	Teach 2	
	Signal – Interface 2, 3, 4, 5 (voltage):	0 V	+V	Uout+	Uout-	$\overline{\text{Uout+}}$	$\overline{\text{Uout-}}$	Teach 1	Teach 2	
	Pin:	1	2	3	4	5	6	7	8	
Type of connection	M12 connector, 5-pin									
2	Signal – Interface 1 (current):	+V	$\overline{\text{Iout+}}$	0 V	Iout+	Teach				
	Signal – Interface 2, 3, 4, 5 (voltage):	+V	$\overline{\text{Uout+}}$	0 V	Uout+	Teach				
	Pin:	1	2	3	4	5				
Type of connection	Cable, 5-pin									
4, B	Signal – Interface 1 (current):	+V	$\overline{\text{Iout+}}$	0 V	Iout+	Teach				
	Signal – Interface 2, 3, 4, 5 (voltage):	+V	$\overline{\text{Uout+}}$	0 V	Uout+	Teach				
	Core color:	BN	GY	WH	GN	BU				

Terminal assignment, 2-axis

Type of connection	M12 connector, 8-pin									
1	Signal – Interface 1 (current):	0 V	+V	Iout+ X	Iout- X	Iout+ Y	Iout- Y	Teach 1	Teach 2	
	Signal – Interface 2, 3, 4, 5 (voltage):	0 V	+V	Uout+ X	Uout- X	Uout+ Y	Uout- Y	Teach 1	Teach 2	
	Pin:	1	2	3	4	5	6	7	8	
Type of connection	M12 connector, 5-pin									
2	Signal – Interface 1 (current):	+V	Iout+ Y	0 V	Iout+ X	Teach				
	Signal – Interface 2, 3, 4, 5 (voltage):	+V	Uout+ Y	0 V	Uout+ X	Teach				
	Pin:	1	2	3	4	5				
Type of connection	Cable, 5-pin									
4, B	Signal – Interface 1 (current):	+V	Iout+ Y	0 V	Iout+ X	Teach				
	Signal – Interface 2, 3, 4, 5 (voltage):	+V	Uout+ Y	0 V	Uout+ X	Teach				
	Core color:	BN	GY	WH	GN	BU				

+V Supply voltage +V DC
 0V Supply voltage ground GND (0 V)
 Teach 1 Input 1 for various teaching functions
 Teach 2 Input 2 for various teaching functions

Uout+ X X axis voltage output
 Uout- X X axis voltage output GND
 Uout+ Y Y axis voltage output
 Uout- Y Y axis voltage output GND

1-axis version
 Uout+ Voltage output
 Uout- Voltage output GND
 $\overline{\text{Uout+}}$ Inverted voltage output
 $\overline{\text{Uout-}}$ Inverted voltage output GND

Iout+ X X axis current output
 Iout- X X axis current output GND
 Iout+ Y Y axis current output
 Iout- Y Y axis current output GND

1-axis version
 Iout+ Current output
 Iout- Current output GND
 $\overline{\text{Iout+}}$ Inverted current output
 $\overline{\text{Iout-}}$ Inverted current output GND

Inclinometers

For dynamic applications
1- and 2-axis measurement

IN51

Analog

Dimensions

Dimensions in mm [inch]

Version with M12 connector

- 1 RGB LED status indicator
- 2 M12 connector

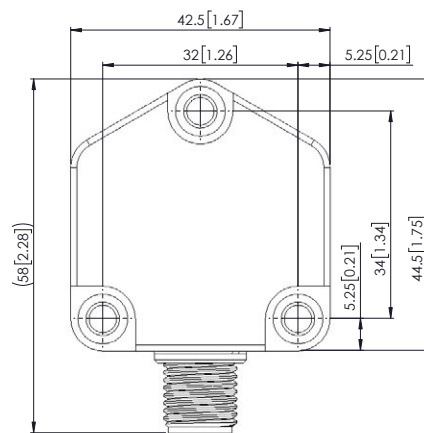
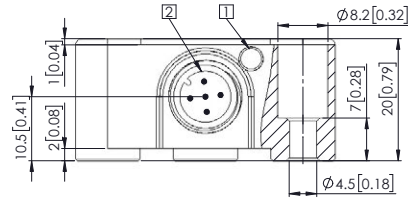

Version with cable

- 1 RGB LED status indicator

