



Model EX602D01

Intrinsically-safe, low profile, industrial, ceramic shear ICP® accel., 100 mV/g, 0.5 to 8000 Hz, side exit, 2-pin connector, single point ISO 17025 accredited calibration

Installation and Operating Manual

**For assistance with the operation of this product,
contact the PCB Piezotronics, Inc.**

Toll-free: 800-959-4464

24-hour SensorLine: 716-684-0001

Fax: 716-684-3823

E-mail: imi@pcb.com

Web: www.imi-sensors.com



INSTRUCTIONS FOR USE - EX(TO)(M)602yzzz/aaa, EX(TO)(M)603yzzz/aaa, EX(TO)(M)606yzzz/aaa, EX(TO)(M)607yzzz/aaa, and EX(TO)(M)608yzzz/aaa Series

<p>Model(s)</p>	<p>EX(TO)(M)602yzzz/aaa, EX(TO)(M)603yzzz/aaa, EX(TO)(M)606yzzz/aaa, EX(TO)(M)607yzzz/aaa, and EX(TO)(M)608yzzz/aaa Series where: Model Options Include: TO – Temperature Output Sensor M – Metric mounting hardware and cable y = One Letter from A to Z denoting revision level (with “M” reserved for customer Special Orders) zzz = Two or Three Numbers 00 to 999 which cable/connector type and sensitivity, filtering, or bias (two numbers) or special order sequential number (up to three digits) aaa = Designates cable length and/or connector type</p>	
<p>Markings</p>	<p>PCB Depew, NY IECEx ETL 25.0046X ETL25ATEX0595X ETL25ATEX0596X Ex ia IIC T4 Ga Ex ec IIC T4 Gc $-40^{\circ}\text{C} \leq T_{\text{amb}} \leq +121^{\circ}\text{C}$ Install per 64371</p>	<p>Class I, Division 1, Groups A – D (Ex ia) Class II, Division 1, Groups E – G Class III, Division 1 Class I, Zone 0, AEx ia IIC T4 Ga Ex ia IIC T4 Ga Class I, Zone 2, AEx ec nC T4 Gc Ex ec nC T4 Gc - Class I, Division 2, Groups A – D (Ex ec nC) $54^{\circ}\text{C} \leq T_{\text{amb}} \leq +121^{\circ}\text{C}$</p>
<p>Putting Into Service</p>	<p>Powering: All ICP® sensors require constant current excitation for proper operation. For this reason, use only PCB constant-current signal conditioners or other approved constant-current sources. The power supply consists of a current-regulated, 18 to 30 VDC source. This power is regulated by a current-limiting circuit, which provides the constant-current excitation required for proper operation of ICP® sensors. In general, battery-powered devices offer versatility for portable, low-noise measurements, whereas line-powered units provide the capability for continuous monitoring. Consult the Vibration Division’s product catalog for more information about signal conditioners. NOTE: <i>Under no circumstances should a voltage be supplied to an ICP® accelerometer without a current-regulating diode or equivalent electrical circuit. This may include ohmmeters, multi-meters and continuity testers.</i></p>	
<p>Safe Use</p>	<p>After completing the system setup, switch on the signal conditioner and allow 1 to 2 minutes for the system to stabilize. The meter (or LED) on the signal conditioner should be reading “green.” This indicates proper operation and you may begin taking measurements. If a faulty condition is indicated (red or yellow reading), first check all system connections, then check the functionality of the cable and signal conditioner. If the system still does not operate properly, consult a PCB factory representative. NOTE: <i>Always operate the accelerometer within the limitations listed on the enclosed Specification Sheet. Operating the device outside these parameters can cause temporary or permanent damage to the sensor.</i> WARNING: <i>Do not separate when Energized.</i></p>	

<p>Assembling</p>	<p>The EX(TO)(M)602yzzz/aaa, EX(TO)(M)603yzzz/aaa, EX(TO)(M)606yzzz/aaa, EX(TO)(M)607yzzz/aaa, and EX(TO)(M)608yzzz/aaa Series have hermetically sealed titanium stainless housings, with a sealed integral cable, and do not require any assembly. Only mounting to the machine being monitored using standard mounting accessories.</p>
<p>Dismantling</p>	<p>Other than removal from the mounting, there is no disassembly of the sensor required to take it out of service.</p>



INDUSTRIAL MONITORING INSTRUMENTATION DIVISION

Piezoelectric ICP® Accelerometers Operating Guide

Operating Guide with Enclosed Warranty Information

3424 Walden Avenue, Depew, New York 14043-2495

Phone (716) 684-0003

Fax (716) 684-3823

Toll Free Line 1-800-959-4IMI

***MANUAL NUMBER: 18405
MANUAL REVISION: A***

ECN NUMBER: 49766

General
OPERATING GUIDE

for use with

PIEZOELECTRIC ICP® ACCELEROMETERS

SPECIFICATION SHEET, INSTALLATION DRAWING AND CALIBRATION INFORMATION ENCLOSED

IMI ASSUMES NO RESPONSIBILITY FOR DAMAGE CAUSED TO THIS PRODUCT AS A RESULT OF PROCEDURES THAT ARE INCONSISTENT WITH THIS OPERATING GUIDE

1.0 INTRODUCTION

Congratulations on the purchase of a quality ICP® industrial sensor. In order to ensure the highest level of performance for this product, it is imperative that you properly familiarize yourself with the correct mounting and installation techniques before attempting to operate this device. If, after reading this manual, you have any additional questions concerning this sensor or its application, feel free to call an Application Engineer at **716-684-0003** or **800-959-4464**.

Proper sensor selection requires special attention to three main areas: sensor design, dynamic expectations, and application environment.

Sensor design encompasses the actual sensing element, the physical material, and component selection for the sensor. Preferred industrial accelerometers employ a shear sensing element with either a quartz or ceramic crystal.

Quartz sensing elements are typically used when long-term stability and minimum output shifts due to temperature changes are desired. Ceramic sensing elements provide excellent resolution and durability in noisy environments, and can be designed to supply low-frequency and high-frequency measurements. Shear-design sensors are preferred because of their inherent insensitivity to adverse environmental influences, such as case or base strain and thermal transients. Internal case isolation and shielding is important in avoiding erroneous signals resulting from ground loops and pick-up of electromagnetic and radio frequency interference. Other critical material selection criteria include non-magnetic stainless steel housing, hermetic sealing, and industrial military connectors. See Figure 1.

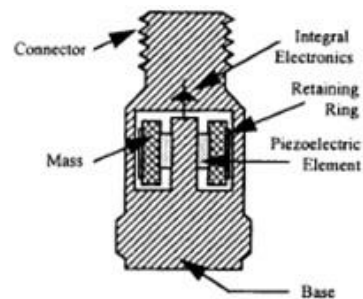

Figure 1. Typical Industrial Shear Mode Accelerometer

Dynamic expectations are application-specific and refer to the frequency range of measurement and the anticipated amplitudes of vibration. After careful review of the machinery to be monitored, minimum and maximum measurement frequency ranges may be established. The minimum measurement frequency is normally related to any sub-harmonics of running speed or any lower frequencies where vibration data is to be collected. The maximum measurement frequency of interest is determined by the maximum number of harmonics of an event like running speed, bearing frequencies, or gear mesh. This measurement frequency range should be well within the specified frequency range of the sensor.

Amplitude range refers to the anticipated levels of vibration to be measured. These values are related to the alarm levels set for the machine. By carefully evaluating the idiosyncrasies of the machinery, the predictive maintenance engineer can estimate the minimum expected vibration levels and ensure that the electrical noise floor of the accelerometer is less than those levels.

The environment of the application is a critical consideration during program implementation. The sensor chosen must be capable of surviving the wide range of conditions to which it is subjected; therefore, take time to evaluate potential conditions, such as high temperatures and chemical contaminants. The specified temperature range of the sensor must conform to the fluctuations of the environmental temperature. If harsh industrial chemicals are present, the sensor requires hermetic sealing and construction that resists corrosion. Finally, specific location of the sensor within the environment must be sensible, as both cable and sensor may be damaged by imprudent installation in heavily traveled, physically punishing areas.

2.0 ICP® ACCELEROMETERS

Enclosed in the back of this guide is a Specification Sheet, which lists the complete performance characteristics of the particular sensor.

All ICP® sensors require a constant current power source for proper operation. A typical sensing system includes an ICP® sensor, ordinary two conductor cable and a basic constant current power supply (as shown in Figure 2).

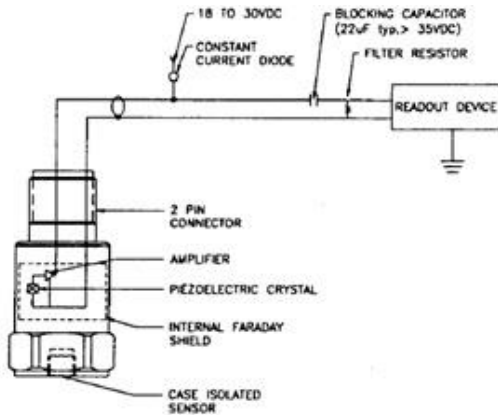

Figure 2. Typical Sensor System

The signal conditioner consists of a well-regulated 18 to 30 VDC source (battery or line-powered), a current-regulating diode (or equivalent constant current circuit), and a capacitor for decoupling (removing the bias voltage) the signal.

The current-regulating device is used in place of a resistor for several reasons. The very high dynamic resistance of the diode yields a source follower gain which is extremely close to unity and independent of

input voltage. Also, the diode can be changed to supply higher currents for driving long cable lengths. Constant current diodes, as shown in Figure 3, should be used in ICP® signal conditioners. **(The correct orientation of the diode within the circuit is critical for proper operation.)** Except for special models, standard ICP® sensors require a minimum of 2 mA for proper operation.

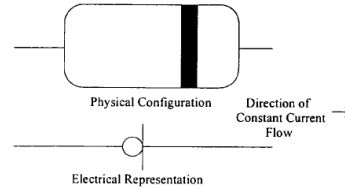

Figure 3. Constant Current Diode

The typical limits for this type of diode are to a 4 mA maximum rating; however, several diodes can be placed in parallel for higher current levels. All line-powered signal conditioners should use higher capacity (up to 20 mA) constant current circuits in place of the diodes, particularly when driving long signal cables (see Section 5).

Decoupling of the data signal occurs at the output stage of the signal conditioner. A 10 to 30 µF capacitor coupled with a resistor shifts the signal level to essentially eliminate the sensor bias voltage. The result is a drift-free AC mode of operation.

3.0 OPTIONAL FEATURES

In addition to standard features, a variety of options are also available. When listed before the model number, the following prefix letters indicate that the sensor is manufactured or supplied with optional features:

- CS - Canadian Standards Association Approved Sensor
- D - Dummy, non-working sensor for display purposes
- EX - Cenelec Approved Sensor
- FM - Factory Mutual Approval Sensor
- HT - High temperature accelerometer (325 °F)
- LB - Low Bias electronics
- LC - Limited Calibration (one point calibration)
- LP - Low Pass filter
- M - Metric mounting hardware and cable length
- U - Usable demonstration sensor (does not meet one or more minor specifications)
- VO - Velocity Output Sensors

MS – Mine Safety Approved Sensors
 TO – Temperature Output Sensor

Note: *Not all sensors are available with the optional prefixes. Contact the factory to discuss special features that may be needed.*

4.0 INSTALLATION OVERVIEW

When choosing a mounting method, consider closely both the advantages and disadvantages of each technique. Characteristics like location, ruggedness, amplitude range, accessibility, temperature, and portability are extremely critical. However, the most important and often overlooked consideration is the effect the mounting technique has on the high-frequency operating range of the accelerometer.

Shown in Figure 4 are six possible mounting techniques and their effects on the performance of a typical piezoelectric accelerometer. (**Note:** *Not all of the mounting methods may apply to your particular sensor.*) The mounting configurations and corresponding graph demonstrate how the high-frequency response of the accelerometer may be compromised as mass is added to the system and/or the mounting stiffness is reduced.

Note: *The low-frequency response is unaffected by the mounting technique. This roll-off behavior is typically fixed by the sensor's built-in electronics. However, when operating AC-coupled signal conditioners with readout devices having an input impedance of less than one megaohm, the low frequency range may be affected.*

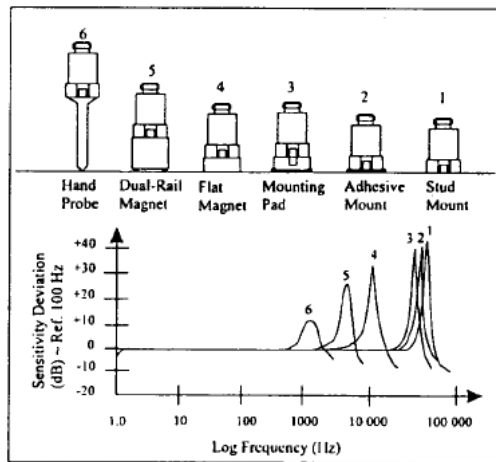
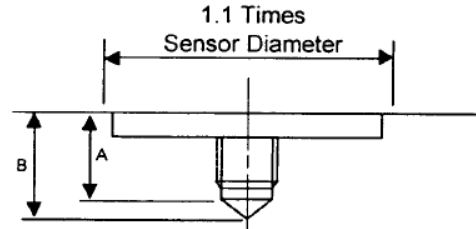

Figure 4. Assorted Mounting Configurations and Their Effects on High Frequency

4.1 STANDARD STUD MOUNT

This mounting technique requires smooth, flat contact surfaces for proper operation and is recommended for permanent and/or secure installations. Stud mounting is also recommended when testing at high frequencies.

Note: *Do NOT attempt mounting on curved, rough, or uneven surfaces, as the potential for misalignment and limited contact surface may significantly reduce the sensor's upper operating frequency range.*



	1/4-28 Stud	1/4-28 Captive Screw
A (in.)	.250	.250
B (in.)	.350	.350
Torque (ft-lb)	2 to 5	2 to 5

Figure 5. Mounting Surface Preparation

STEP 1: First, prepare a smooth, flat mounting surface and then drill and tap a mounting hole in the center of this area as shown in Figure 5.

A precision-machined mounting surface with a minimum finish of 63 μin (0.0016 mm) is recommended. (If it is not possible to properly prepare the machine surface, consider using an adhesive mounting pad as a possible alternative.) Inspect the area, checking that there are no burrs or other foreign particles interfering with the contact surface.

STEP 2: Wipe clean the mounting surface and spread on a light film of grease, oil, or similar coupling fluid prior to installation. See Figure 6.

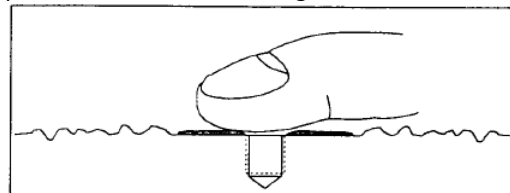

Figure 6. Mounting Surface Lubrication

Adding a coupling fluid improves vibration transmissibility by filling small voids in the mounting surface and increasing the mounting stiffness. For

semi-permanent mounting, substitute epoxy or another type of adhesive.

STEP 3: Hand-tighten the sensor/mounting stud to the machine, then secure the sensor with a torque wrench to the mounting surface by applying the recommended mounting torque. (See enclosed specification data sheet for proper mounting torque.)

It is important to use a torque wrench during this step. Under-torqueing the sensor may not adequately couple the device; over-torqueing may result in stud failure and possibly permanent damage.

4.2 ADHESIVE MOUNT

Adhesive mounting is often used for temporary installation or when the machine surface cannot be adequately prepared for stud mounting. Adhesives like hot glue or wax work well for temporary mounts; two-part epoxies and quick-bonding gels provide a more permanent mount.

Note: *Adhesively-mounted sensors often exhibit a reduction in high-frequency range. Generally, smooth surfaces and stiff adhesives provide the best frequency response. Contact the factory for recommended epoxies.*

METHOD 1 – Adhesive mounting base

This method involves attaching a base to the machine surface, then securing the sensor to the base. This allows for easy removal of the accelerometer.

STEP 1: Prepare a smooth, flat mounting surface. A minimum surface finish of 63 μin (0.0016 mm) generally works best.

STEP 2: Stud-mount the sensor to the appropriate adhesive mounting base according to the guidelines set forth in **STEPS 2** and **3** of the Stud Mount Procedure.

STEP 3: Place a small portion of adhesive on the underside of the mounting base. Firmly press down on the assembly to displace any extra adhesive remaining under the base. See Figure 7.

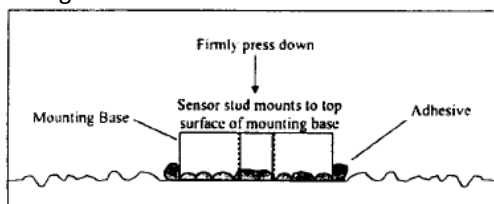

Figure 7. Mounting Base: Adhesive Installation

METHOD 2 – Direct Adhesive Mount

For restrictions of space or for convenience, most sensors (with the exception of integral stud models) can be adhesive-mounted directly to the machine surface.

STEP 1: Prepare a smooth, flat mounting surface. A minimum surface finish of 63 μin (0.0016 mm) generally works best.

STEP 2: Place a small portion of adhesive on the underside of the sensor. Firmly press down on the top of the assembly to displace any adhesive. Be aware that excessive amounts of adhesive can make sensor removal difficult. See Figure 8.

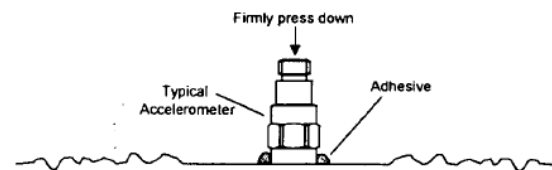

Figure 8. Direct Adhesive Mounting

4.3 MAGNETIC MOUNT

Magnetic mounting provides a convenient means for making portable measurements and is commonly used for machinery monitoring and other portable or trending applications.

Note: *The correct magnet choice and an adequately prepared mounting surface are critical for obtaining reliable measurements, especially at high frequencies. Poor installations can cause as much as a 50% drop in the sensor frequency range.*

Not every magnet is suitable for all applications. For example, rare earth magnets are commonly used because of their high strength. Flat magnets work well on smooth, flat surfaces, while dual-rail magnets are required for curved surfaces. In the case of non-magnetic or rough surfaces, it is recommended that the user first weld, epoxy, or otherwise adhere a steel mounting pad to the test surface. This provides a smooth and repeatable location for mounting.

STEP 1: After choosing the correct magnet type, inspect the unit, verifying that the mounting surfaces are flat and smooth. See Figure 9.

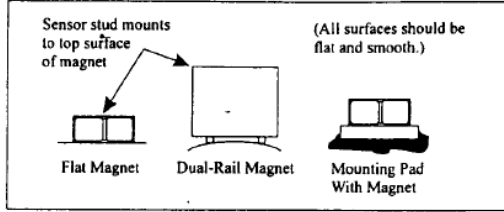

Figure 9. Magnet Types

STEP 2: Stud-mount the accelerometer to the appropriate magnet according to the guidelines set forth in **STEPS 2** and **3** of the Stud Mount Procedure.

STEP 3: Prepare a smooth, flat mounting surface. A minimum surface finish of 63 μin (0.0016 mm) generally works best. After cleaning the surface and checking for burrs, wipe on a light film of silicone grease, machine oil, or similar-type coupling fluid.

STEP 4: Mount the magnet/sensor assembly to the prepared test surface by gently “rocking” or “sliding” it into place. See Figure 10.

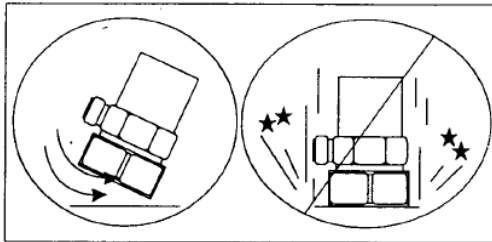

Figure 10. Magnet Mounting

Note: *Magnetically mounting accelerometers carelessly has the potential to generate very high (and very damaging) g levels. To prevent damage, install the assembly gently. If unsure, please contact the factory for assistance.*

4.4 HANDHELD OR PROBE TIP MOUNT

This method is NOT recommended for most applications. It is generally used where access to machinery may be a safety concern. Both the accuracy and repeatability at low (<5 Hz) and high frequency (>1 kHz) ranges are questionable.

5.0 CABLING

The selection of connectors and cables has a direct impact on the ruggedness and reliability of the sensor installation. A consideration when dealing with cables is the way in which the cable conductors are terminated.

ICP® accelerometers are internally amplified, two-wire accelerometers. Connections to the sensor require two leads: one for the power and signal, and the other for the common and signal return. Often, coaxial cables are used since only two conductors are needed. Coaxial cables are less expensive. With coaxial cables, however, erroneous signals can be introduced into sensor systems through ground loops, electromagnetic interference, or radio frequency interference (EMI or RFI). To avoid ground loops, there should only be one ground in the system.

It is recommended for permanent installations that the sensor be case-isolated and internally shielded with a dual-case design and use a two-conductor shielded cable to insure clean vibration signal transmission. Two-conductor shielded cables allow the signal and the signal return (common) to be fully shielded from the sensor to the readout equipment. To insure that ground loop signals are not induced, the shield should only be terminated at one end. Typically, the shield of a two-conductor shielded cable is left open or not connected at the sensor end and is tied to earth ground at the instrumentation end.

Operation over long cables may affect the frequency response of ICP® accelerometers, and introduce low frequency noise and high frequency distortion when an insufficient current is available to drive cable capacitance.

Unlike charge mode systems, where the system noise is a function of cable length, ICP® sensors provide a high voltage, low impedance output well-suited for driving long cables through harsh environments. While there is virtually no increase in noise with ICP® sensors, the capacitive loading of the longer cable may be distort or filter higher frequency signals depending on the supply current and the output impedance of the sensor.

Generally, this signal distortion is not a problem with lower frequency testing within a range up to 1,000 Hz. However, when monitoring higher frequency vibrations traveling over cables longer than 500ft, the possibility of signal distortion exists.

The maximum frequency that can be transmitted over a given cable length is a function of both the cable capacitance and the ratio of the peak signal voltage to the current available from the signal conditioner according to:



$$f_{\max} = \frac{10^9}{2\pi CV} \quad (\text{Equation 1})$$

[L_c-1]

- Where, f_{max} = maximum frequency (hertz)
C = cable capacitance (picofarads)
V = maximum peak output from sensor (volts)
L_c = constant current from signal conditioner (mA)
10⁹ = scaling factor to equate units

Note that in this equation, 1 mA is subtracted from the total current supplied to sensor (L_c). This is done to compensate for powering the internal electronics. Also, note that these are typical values only.

When driving long cables, Equation 1 shows that, as the length of the cable, peak voltage output or maximum frequency of interest increases, a greater constant current will be required to drive the signal.

The nomograph on page 12 of this manual provides a simple, graphical method for obtaining the expected maximum frequency capability of an ICP® measurement system. The maximum peak signal voltage amplitude, cable capacitance and supplied constant current must be known or presumed.

For example, when running at 100 ft (30.5 m) cable with a capacitance of 30 pF/ft, the total capacitance is 3,000pF. This value can be found along the diagonal cable capacitance lines. Assuming the sensor operates at a maximum output range of 5 volts and the constant current available from the power supply is 2 mA, the ratio on the vertical axis can be calculated to equal 5. The intersection of the total cable capacitance and this ratio result in a maximum frequency of approximately 10.2 kHz.

The nomograph does not indicate whether the frequency amplitude response at a point is flat, rising or falling. For precautionary reasons, it is good general practice to increase the constant current (if possible) to the sensor (within its maximum limit) so that the frequency determined from the nomograph is approximately 1.5 to 2 times greater than the maximum frequency of interest.

Note: Higher current levels will deplete battery-powered signal conditioners at a faster rate. Also, any current not used by the cable goes directly to power the internal electronics and will create heat. This may cause the sensor to

exceed its maximum temperature specification. For this reason, do not supply excessive current over short cable runs or when testing at elevated temperatures.

5.1 CABLE CONNECTOR PROCEDURE

Care and attention to installation is essential, as the reliability and accuracy of your system is no better than that of the output cable.

STEP 1: Ascertain that you have ordered the correct cable type.

As with sensors, no cable can satisfy all applications. Special low-noise cabling should be used with high impedance, charge-output devices. ICP® sensors usually operate with any ordinary tow-wire cable. Industrial applications often require twisted/shielded cables to reduce the effects of EMI and RFI. PTFE-jacketed cabling may be necessary to withstand corrosive environments.

STEP 2: Connect the cable to the accelerometer. A small amount of thread-locking compound placed on the connector prior to attachment helps secure the cable during testing. In harsh environments, the connection can be sealed with silicone rubber, O-rings, and flexible heat-shrink tubing.

STEP 3: Plug the connector of the cable into the mating sensor connector. Then, holding the sensor stationary, secure the connector in place by tightening down the attached threaded cable sleeve.

STEP 4: Route the cable to the signal conditioner, making certain to stress-relieve the sensor/cable connection and minimize motion by clamping the cable at regular intervals.

Common sense should be used to avoid physical damage and minimize electrical noise. For instance, avoid routing cables near high-voltage wires. Do not route cables along floors or walkways where they be stepped on or become contaminated. Shielded cables should have the shield grounded at one end only, normally at the instrumentation end.

STEP 5: Finally, connect the remaining cable end to the signal conditioner or readout device. To dissipate charge that may have accumulated in the cable short the signal to ground prior to attachment.

6.0 POWERING

All ICP® sensors require constant current excitation for proper operation. For this reason only use approved constant-current sources. A typical system schematic is shown in Figure 11.

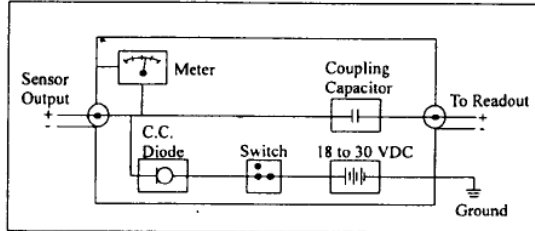

Figure 11. Typical System Schematic

The power supply consists of a regulated 18 to 30 VDC source. In general, battery-powered devices offer versatility for portable, low-noise measurements, whereas line-powered units provide the capability for continuous monitoring. This power is regulated by a current-limiting circuit, which provides the constant-current excitation required for proper operation of sensors with integral electronics.

Note: Under no circumstances should a voltage be supplied to an ICP® accelerometer without a current-regulating diode or equivalent electrical circuit.

A capacitor at the output stage of the device removes the sensor output bias voltage from the measurement signal. This provides a zero-based, AC-coupled output compatible with most standard readout devices.

Today, many FFT analyzers, data acquisition modules, and data collectors have constant-current excitation for direct use with ICP® sensors. However, before using this feature, check that the supply voltage and constant current are adequate for use with your sensor. Please contact the respective signal conditioner manufacturer or check the product manual for more information.

7.0 OPERATING

After completing the system setup, switch on the conditioner, the meter (or LED) and allow the sensor to power up. If a faulty condition is monitored, first check all system connections, then check the functionality of the cable and signal conditioner. If

the system still does not operate properly, consult an IMI Application Engineer.

Note: Always operate the accelerometer within the limitations listed on the Specification Sheet of your sensor. Operating the device outside of its parameters can cause temporary or permanent damage to the sensor.

8.0 ACCELEROMETER CALIBRATION

Note: It is good measurement practice to verify the performance of each accelerometer before and after each measurement.

Accelerometers are precision measuring instruments. They are highly engineered to provide accurate electrical signals representative of the vibration being monitored. Each sensor is calibrated by comparison to a known acceleration level. Some calibrations include frequency response curves, resonant frequency measurements, transvers sensitivity, and many other valuable tests. Applications requiring a high degree of accuracy or those in plants requiring certification and traceability require full calibration test results.

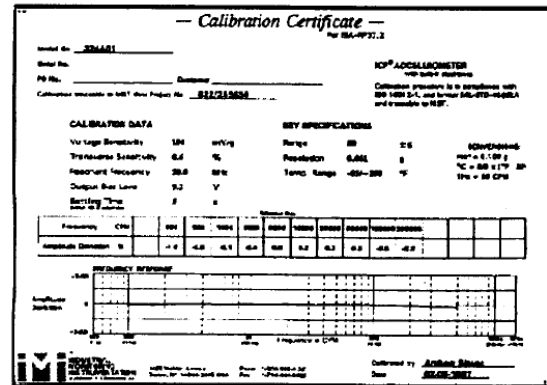

Figure 12. Typical Calibration Certificate

Some applications have much less stringent requirements for calibration certification. Simple sensitivity measurements at a single frequency may be sufficient; operational verification and certificates of conformance to published specifications may satisfy many plants' calibration needs. Reducing the final calibration requirements reduces the cost of manufacturing the sensor and should lower the price for predictive maintenance users.

Periodic recalibration may be required by plants with strict certification and traceability requirements. It is always recommended that the user has the sensor recalibrated periodically, particularly if the sensor has experienced a very high shock level or extreme temperatures for extended periods of time. Some plants develop in-house calibration capabilities for periodically verifying the performance of accelerometers. Products are available that provide a set 1 g-acceleration level at a fixed frequency for quick sensor checking.

For these reasons, it is recommended that a recalibration cycle be established for each accelerometer. This schedule is unique and is based on a variety of factors, such as extent of use, environmental conditions, accuracy requirements, trend information obtained from previous calibration records, contractual regulations, frequency of “cross-checking” against other equipment, manufacturer recommendation, and any risk associated with incorrect readings. International standards, such as ISO 10012-1, provide insight and suggested methods for determining recalibration intervals for most measuring equipment. With the above information in mind and under “normal” circumstances, a conservative suggestion of 12 to 24 month recalibration cycle for most piezoelectric accelerometers is advised.

8.1 SENSOR CALIBRATION

Accelerometer recalibration services are typically performed by IMI’s internal metrology laboratory. (Other international and private laboratories are also available.) The IMI laboratory is certified to ISO 9001, complies with ISO 10012-1 (and former MIL-STD-45662A), and uses equipment directly traceable to NIST. This assures an accurate calibration of relevant specifications.

The following includes a broad overview of the Back-to-Back Calibration technique normally used when calibrating accelerometers. This technique provides a quick and easy method for determining the sensitivity of a test accelerometer over a wide frequency range.

8.2 BACK-TO-BACK CALIBRATION THEORY

Back-to-back calibration is perhaps the most common method for determining the sensitivity of

piezoelectric accelerometers. This method relies on a simple comparison to a previously calibrated accelerometer, typically referred to as a reference standard, as shown in Figure 12.

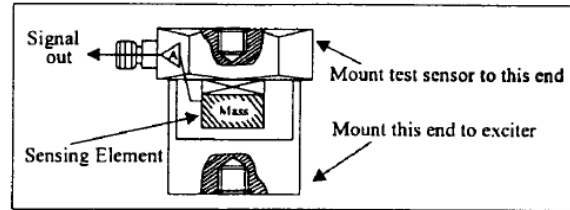

Figure 12. Reference Standard Accelerometer

These high-accuracy devices, which are directly traceable to a recognized standards laboratory, are designed for stability, as well as configured to accept a test accelerometer. By mounting a test accelerometer to the reference standard and then connecting this combination to a suitable vibration source, it is possible to vibrate both devices and compare the data as shown in Figure 13. (Test setups may be automated and vary, depending on the type and number for accelerometers being calibrated.)

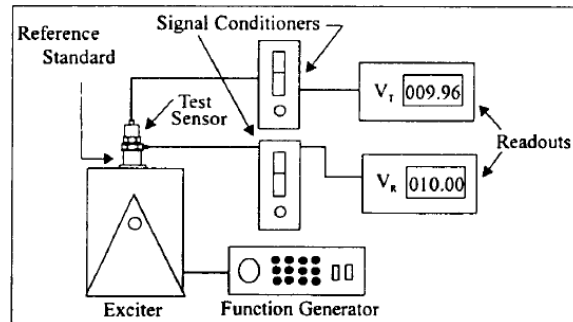

Figure 13. Typical Back-to-Back Calibration System

Because the acceleration is the same on both sensors, the ratio of their outputs (V_T/V_R) must also be the ratio of their sensitivities. With the sensitivity of the reference standard (S_R) known, the exact sensitivity of the test sensor (S_T) is easily calculated by using the following equation:

$$S_T = S_R \left(\frac{V_T}{V_R} \right)$$

By varying the frequency of the vibration, the sensor may be calibrated over its entire operating frequency range. The typical response of an unfiltered accelerometer is shown in Figure 14.

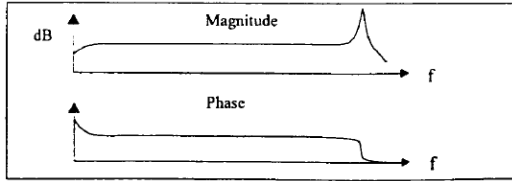

Figure 14. Typical Test Accelerometer Response

9.0 TROUBLESHOOTING

Piezoelectric sensors are dynamic measuring equipment. They use piezoelectric sensing elements to convert or transduce the mechanical phenomena to an electrical signal. The mechanical parameter may be force, pressure or vibration. The raw electrical signal from a piezoelectric charge element is a high impedance signal. This charge signal is normally converted to a low impedance voltage signal by either an external charge amplifier or an external voltage amplifier. The cables between the charge sensor and the amplifier must be high quality, low noise cable and must be kept as short as possible. Figure 15 shows a typical high impedance system.

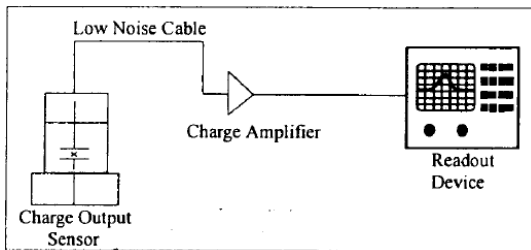

Figure 15. High Impedance System Connection

Internally amplified sensors employ miniature amplifiers to convert the high impedance charge signal into a low impedance voltage signal. These amplifiers are internal to the sensor, and therefore, do not require low noise cables or external amplifiers. These amplifiers have set gain so that output sensitivities are standardized.

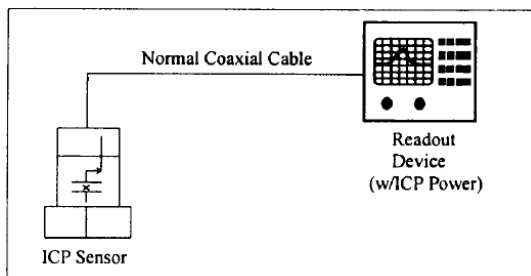

Figure 16. Sensor with Integral Electronics System Connector

ICP® sensors are two-wire sensors. They are powered with a constant current DC source. The power supply is typically 18 to 30 volts DC current limited via a constant current between 2 and 20 mA. Typical battery operated supplies offer 2mA of constant current to extend battery life while continuous monitoring systems offer more current in order to drive longer cables. Figure 16 shows a typical system for a sensor with integral electronics.

The signal output of a sensor with integral electronics is a low impedance voltage signal proportional to the dynamic measurement such as force, pressure, or vibration. This voltage signal is carried on a DC bias voltage. The AC dynamic signal is superimposed on the DC bias voltage and is allowed to swing between the supply voltage and ground as shown in Figure 17. Unlike an operational amplifier that requires a plus and minus supply and allows the signal to “ride” on ground and “swing” between the plus and minus “rails,” the sensor with integral electronics requires the output signal to be DC biased.

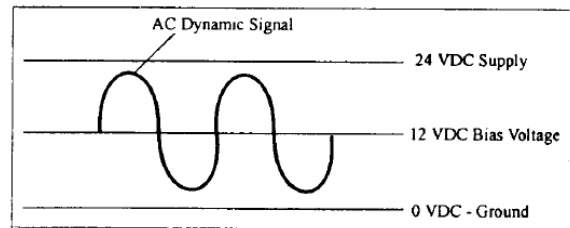

Figure 17. Sensor DC Bias Voltage

This DC bias voltage is an excellent diagnostic tool. The voltage provides a means of verifying that the amplifier is “turned on.” Typical input/output power supplies will block this DC bias voltage at the output via a blocking capacitor in order to AC couple the signal to readout devices. By “teeing” off the input into a DC volt meter, as shown in Figure 18, the bias voltage can be measured.

While measuring the supply voltage, the bias voltage can be measured after the sensor is plugged in. If the meter stays at supply, something in the system is open or not connected. If the meter reads “0,” something in the system is shorted. If the meter reads within the bias voltage range of the sensor, then the sensor and cabling are functioning properly.

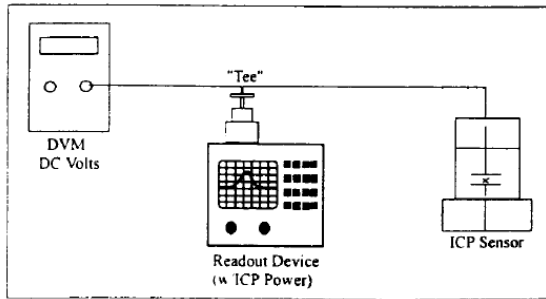

Figure 18. DC Bias Voltage Measurement

10.0 REPAIR/RETURN PROCEDURE

Because of the nature of most IMI instrumentation, field repair is typically NOT recommended and may void any warranty. If factory service is required, contact IMI for a **RETURN MATERIAL AUTHORIZATION (RMA)** number prior to sending equipment to the factory. Please have information available, such as model and serial number. Also, to insure efficient service, be sure to include a written description of the symptoms and problems with the equipment to a local sales representative or distributor, or contact IMI if none are located in your area.

Customers outside the U.S. should consult their local IMI distributor for information on returning equipment. For exceptions, please contact the International Sales department at IMI to request shipping instructions and an

RMA. For assistance, please call **(716) 684-0003**, or fax us at **(716) 684-3823**. You may also receive assistance via e-mail at imi@pcb.com or visit our website at www.pcb.com.

11.0 CUSTOMER SERVICE/WARRANTY

IMI, a division of PCB Piezotronics, guarantees **Total Customer Satisfaction**. If, at any time, for any reason, you are not completely satisfied with any IMI product, IMI will repair, replace or exchange it at no charge. You may also choose to have your purchase price refunded.

IMI instrumentation is warranted against defective material workmanship for 1 year unless otherwise expressly specified. Damage to instruments caused by incorrect power or misapplication, is not covered by warranty. *If there are any questions regarding power, intended application, or general usage, please consult with your local sales contact or distributor.* Batteries or expendable hardware items are not covered by warranty.

IMI offers to all customers, at no charge, 24-hour phone support. This service makes product or application support available to our customers, day or night, seven days a week. When unforeseen problems or emergency situations arise, call the **IMI Hot Line at (716) 684-0003**, and an application specialist will assist you.

Cable Driving Nomograph

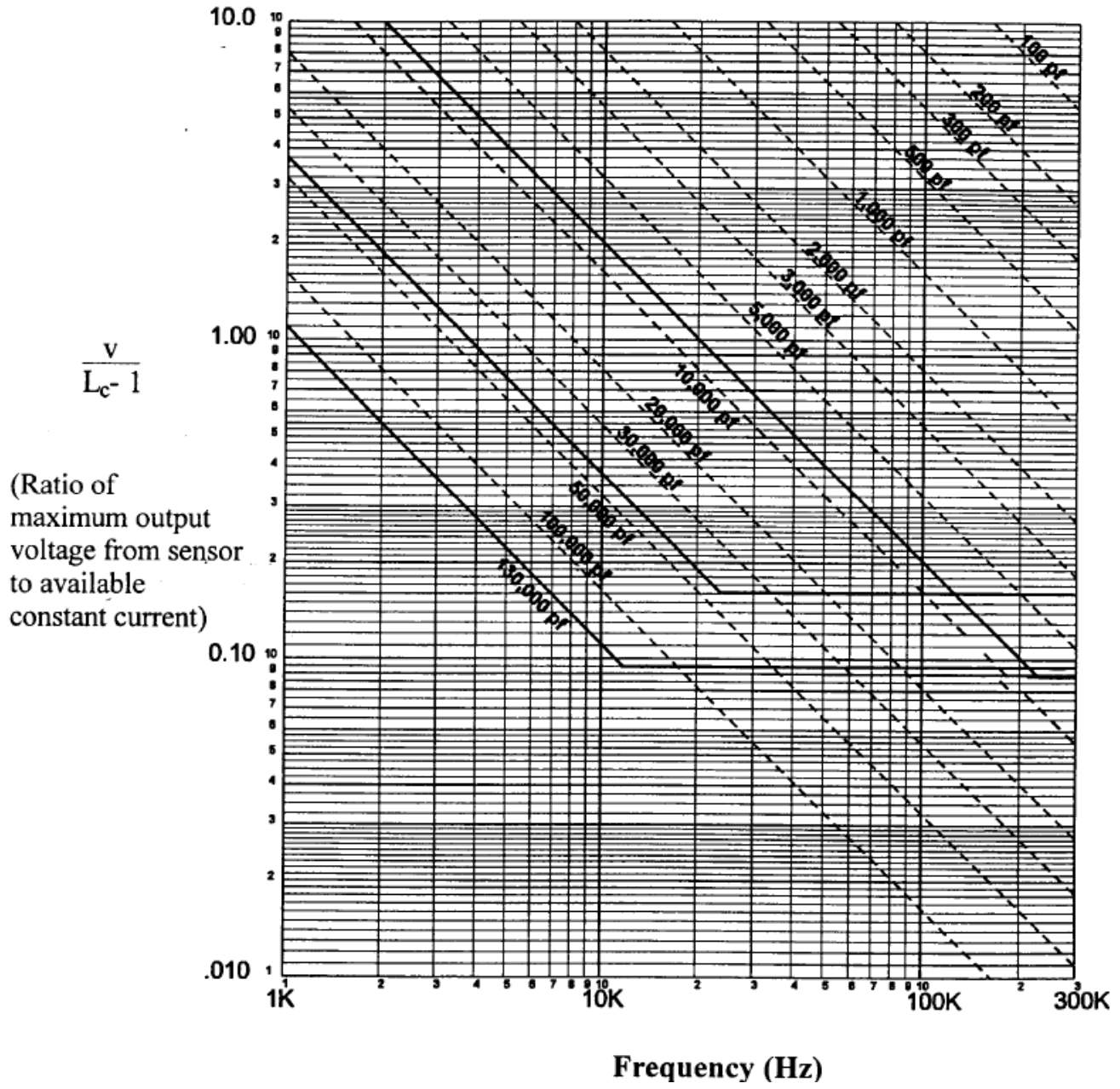

	ENGLISH	SI	
Performance			
Sensitivity(± 10 %)	100 mV/g	10.2 mV/(m/s ²)	[1]
Measurement Range	± 50 g	± 490 m/s ²	
Frequency Range(± 3 dB)	30 to 480,000 cpm	0.5 to 8,000 Hz	[2]
Resonant Frequency	1,500 kcpm	25 kHz	[3]
Broadband Resolution	350 µg	3,434 µm/sec ²	[3]
Non-Linearity	± 1 %	± 1 %	[4]
Transverse Sensitivity	≤ 7 %	≤ 7 %	
Environmental			
Overload Limit(Shock)	5,000 g pk	49,050 m/s ² pk	
Temperature Range	-65 to +250 °F	-54 to +121 °C	
Temperature Response	See Graph	See Graph	[3]
Enclosure Rating	IP68	IP68	
Electrical			
Settling Time(within 1% of bias)	≤ 2.0 sec	≤ 2.0 sec	
Discharge Time Constant	≥ 0.3 sec	≥ 0.3 sec	
Excitation Voltage	18 to 28 VDC	18 to 28 VDC	
Constant Current Excitation	2 to 20 mA	2 to 20 mA	
Output Impedance	< 150 Ohm	< 150 Ohm	
Output Bias Voltage	8 to 12 VDC	8 to 12 VDC	
Spectral Noise(10 Hz)	8.0 µg/√Hz	78.5 (µm/sec ²)/√Hz	[3]
Spectral Noise(100 Hz)	5 µg/√Hz	49.1 (µm/sec ²)/√Hz	[3]
Spectral Noise(1 kHz)	4 µg/√Hz	39.2 (µm/sec ²)/√Hz	[3]
Electrical Isolation(Case)	> 10 ⁸ Ohm	> 10 ⁸ Ohm	
Physical			
Size (Length x Height x Width)	1.65 in x 0.845 in x 0.74 in	41.9 mm x 21.5 mm x 18.8 mm	
Weight	2.61 oz	74.0 gm	
Mounting Thread	1/4-28 Male	No Metric Equivalent	[5]
Mounting Torque	2 to 5 ft-lb	2.7 to 6.8 Nm	
Sensing Element	Ceramic	Ceramic	
Sensing Geometry	Shear	Shear	
Housing Material	Stainless Steel	Stainless Steel	
Sealing	Welded Hermetic	Welded Hermetic	
Electrical Connector	2-Pin MIL-C-5015	2-Pin MIL-C-5015	
Electrical Connection Position	Side	Side	

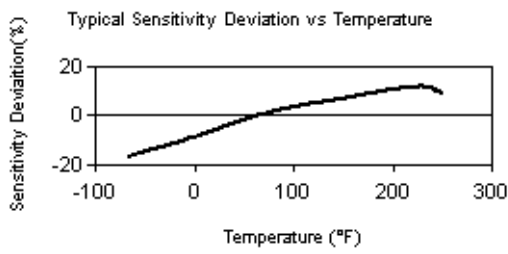

All specifications are at room temperature unless otherwise specified.
 In the interest of constant product improvement, we reserve the right to change specifications without notice.
 ICP® is a registered trademark of PCB Piezotronics, Inc.

OPTIONAL VERSIONS		
Optional versions have identical specifications and accessories as listed for the standard model except where noted below. More than one option may be used.		
EX - Hazardous Area Approval- contact factory for specific approvals		
Hazardous Area Approval	EEx nL IIC T4, -40 °C ≤ Ta ≤ 121 °C, II 3 G	EEx nL IIC T4, -40 °C ≤ Ta ≤ 121 °C, II 3 G
Hazardous Area Approval	EEx ia IIC T4, -40 °C ≤ Ta ≤ 121 °C, II 1 G	EEx ia IIC T4, -40 °C ≤ Ta ≤ 121 °C, II 1 G
Hazardous Area Approval	Cl I, Div I, Groups A, B, C, D; Cl II, Div I, Groups E, F, G; Cl III, Div I	Cl I, Div I, Groups A, B, C, D; Cl II, Div I, Groups E, F, G; Cl III, Div I
Hazardous Area Approval	Ex ia IIC T4, AExia IIC, T4	Ex ia IIC T4, AExia IIC, T4
Hazardous Area Approval	Cl I, Div 2, Groups A, B, C, D; ExnL IIC T4, AExnA IIC T4	Cl I, Div 2, Groups A, B, C, D; ExnL IIC T4, AExnA IIC T4
M - Metric Mount Supplied Accessory: Model M081B97 Captive Mounting Bolt, M6 x 1 x 25 mm long, hex head (1)		
TO - Temperature Output		
Temperature Output Range	+36 to +250 °F	+2 to +121 °C
Temperature Scale Factor	5.56 mV/°F + 32	+10 mV/°C
Electrical Connections(Pin A)	Acceleration Output	Acceleration Output
Electrical Connections(Pin B)	Ground	Ground
Electrical Connections(Pin C)	Temperature Output	Temperature Output

NOTES:
 [1] Conversion Factor 1g = 9.81 m/s².
 [2] The high frequency tolerance is accurate within ±10% of the specified frequency.
 [3] Typical.
 [4] Zero-based, least-squares, straight line method.
 [5] 1/4-28 has no equivalent in S.I. units.
 [6] See PCB Declaration of Conformance PS023 or PS060 for details.

SUPPLIED ACCESSORIES:
 Model 081B97 Captive Mounting Bolt 316SS - 7/16 HEX 1/4-28 UNF (1)

Entered: ND	Engineer: BAM	Sales: JL	Approved: NJF	Spec Number:
Date: 01/12/2023	Date: 01/12/2023	Date: 01/12/2023	Date: 01/12/2023	29429

	Phone: 800-959-4464 Fax: 716-684-3823 E-Mail: imi@pcb.com
3425 Walden Avenue, Depew, NY 14043	

PCB Piezotronics Inc. claims proprietary rights in the information disclosed hereon. Neither it nor any reproduction thereof will be disclosed to others without the written consent of PCB Piezotronics Inc.

29425

REVISIONS		
REV	DESCRIPTION	DIN
A	UPDATED MOUNTING BOLT	42938

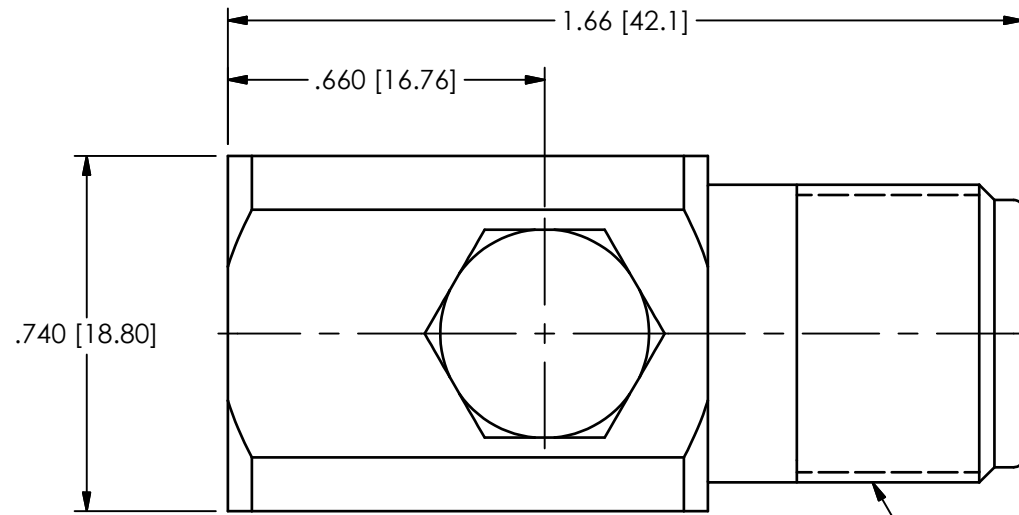

ELECTRICAL CONNECTOR
5/8-24 UNEF-2A
2 PIN (MIL-C-5015)

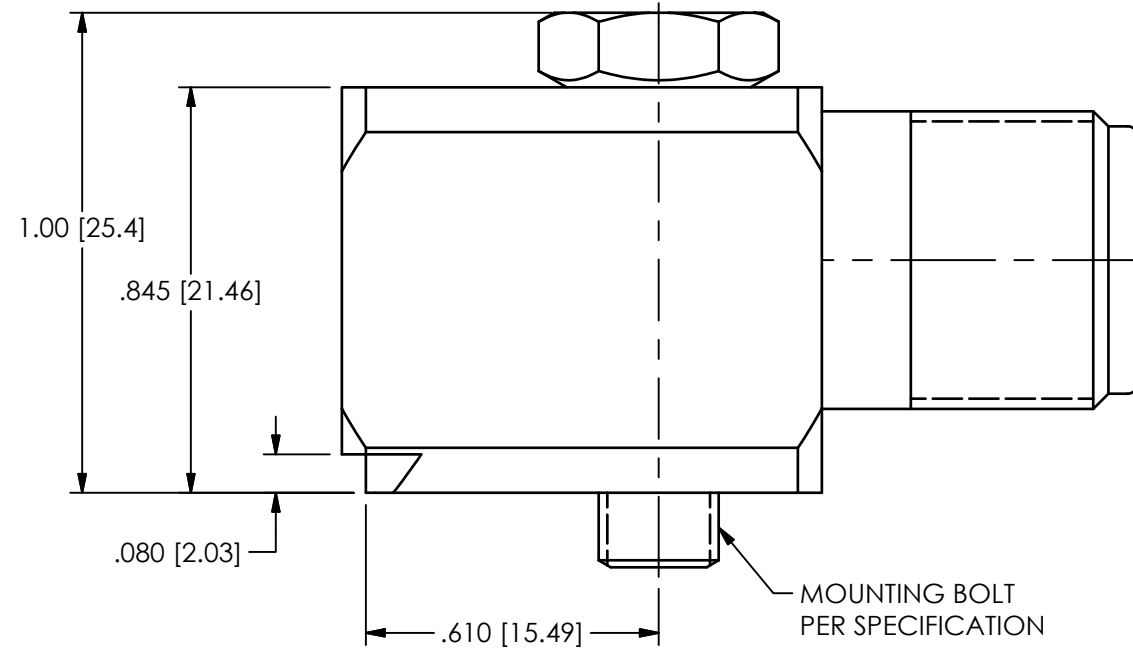

MOUNTING BOLT
PER SPECIFICATION

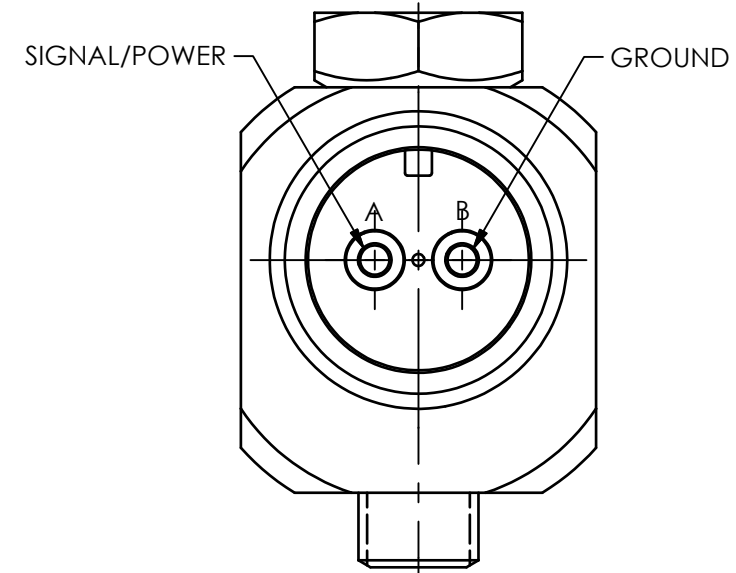

UNLESS OTHERWISE SPECIFIED TOLERANCES ARE:		DRAWN		CHECKED		ENGINEER		PCB PIEZOTRONICS™	
DIMENSIONS IN INCHES	DIMENSIONS IN MILLIMETERS [IN BRACKETS]	JDM	5/20/14	ECB	5/20/14	BAM	5/20/14	3425 WALDEN AVE. DEPEW, NY 14043 (716) 684-0001 E-MAIL: sales@pcb.com	
DECIMALS XX ±.03 XXX ±.010	DECIMALS X ±0.8 XX ±0.25	TITLE OUTLINE DRAWING MODEL 602D01 SERIES ACCELEROMETER							
ANGLES ± 2 DEGREES	ANGLES ± 2 DEGREES								
FILLETS AND RADII .003 - .005	FILLETS AND RADII 0.07 - 0.13	CODE IDENT. NO. 52681		DWG. NO. 29425		SCALE: 2.5X		SHEET 1 OF 1	

jmorawski 10:07 5/20/2014

64371

PCB Piezotronics Inc. claims proprietary rights in the information disclosed hereon. Neither it nor any reproduction thereof will be disclosed to others without the written consent of PCB Piezotronics Inc.

SCHEDULE DRAWING

NO MODIFICATIONS PERMITTED WITHOUT REFERENCE TO THE NOTIFIED BODY

REVISIONS		
REV	DESCRIPTION	DIN
B	PROTECTION UPDATE	56048

NON-HAZARDOUS / SAFE AREA HAZARDOUS AREA ZONE 0

CABLE

TRANSDUCER

VIN ≤ +24 VOLTS

SINGLE CHANNEL

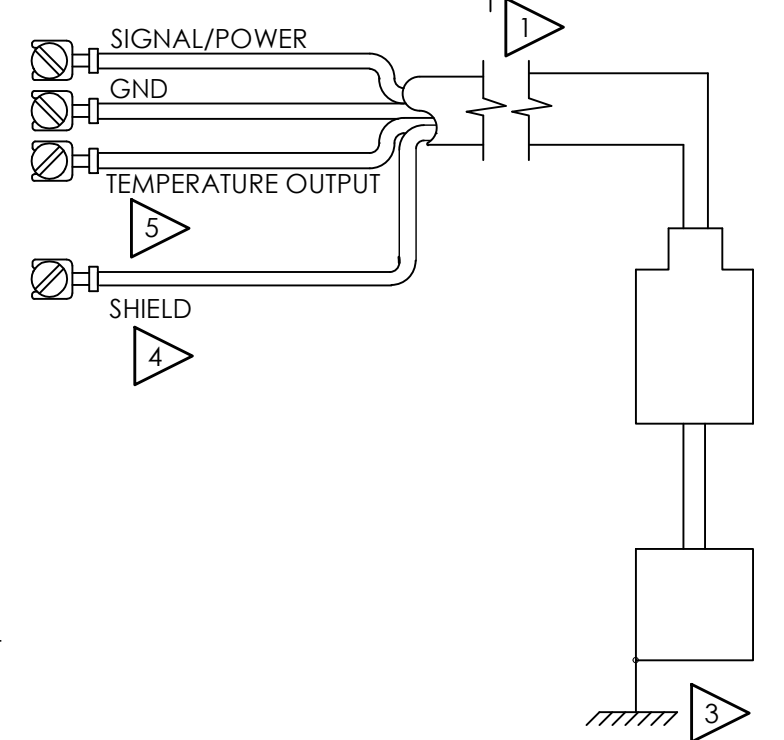
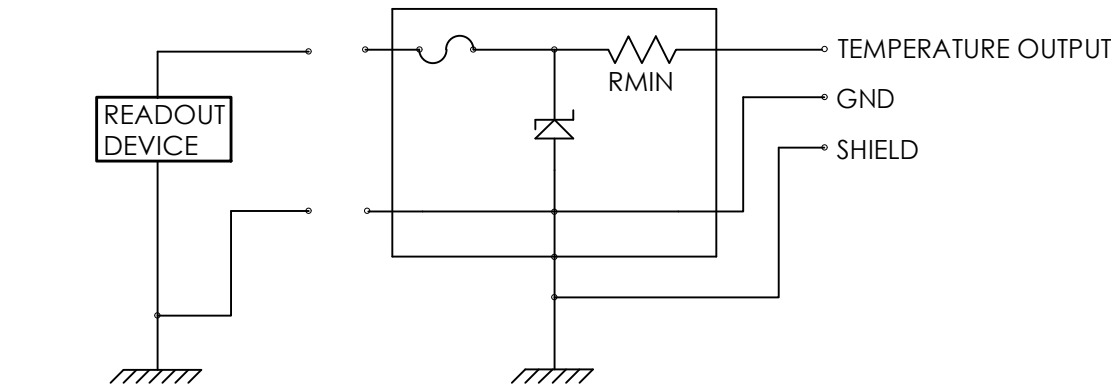
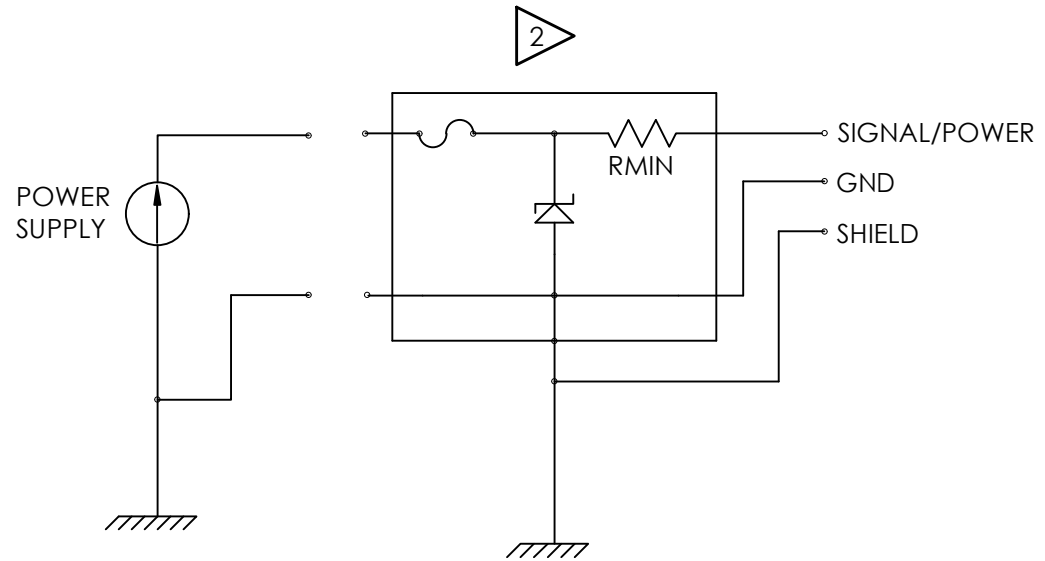

- 5 ONLY APPLICABLE FOR "TO" OPTION
- 4 SHIELDS TO BE EARTHED AT BARRIER ENDS
- 3 THE INSTALLER SHALL INSURE THAT THE TRANSDUCER MOUNTING STRUCTURE IS AT THE SAME GROUNDING POTENTIAL AS THE BARRIER GROUND. TOTAL EARTH LOOP IMPEDANCE SHALL BE LESS THAN 1 OHM
- 2 BARRIER WILL BE MOUNTED IN AN ENCLOSURE THE SUITABILITY OF WHICH WILL BE DETERMINED BY LOCAL AUTHORITIES.

1 ENTITY APPLICATION

BARRIER	I.S. APPARATUS
$V_{oc}/U_o \leq V_{MAX} / U_I$	
$I_{sc}/I_o \leq I_{MAX} / I_I$	
$C_a/C_o > C_I + C_{CABLE}$	
$L_a/L_o > L_I + L_{CABLE}$	
$P_o \leq P_I$ (CENELEC ONLY)	

BARRIERS WITHIN THE SPECIFIED LIMITATIONS ARE PERMITTED

ENTITY PARAMETERS

CONNECTOR VERSION	INTEGRAL CABLE VERSION
$U_i = 28V$	$U_i = 28V$
$I_i = 120 mA$	$I_i = 120 mA$
$P_i = 0.84 W$	$P_i = 0.84 W$
$C_i = 46.5 nF$	$C_i = 77 nF$
$L_i = 0 \mu H$	$L_i = 152.5 \mu H$

NOTE: COMBINED I_i FROM EACH BARRIER CANNOT EXCEED I_i ABOVE CERTIFIED BY THE APPROPRIATE APPROVAL AUTHORITY FOR CONNECTION TO THE FOLLOWING AREAS:

ZONE 0
Ex ia IIC T4 Ga

NOTES: FOR MODELS INTEGRAL CABLE SERIES, C_i IS SPECIFIED AT A MAXIMUM CABLE LENGTH OF 500 FT. FOR SHORTER CABLE LENGTHS, C_i IS DECREASED BY 61 pF/FT

UNLESS OTHERWISE SPECIFIED

DIMENSIONS ARE IN INCHES	
DECIMALS	X ± .05
	XX ± .01
	XXX ± .005
	XXXX ± .0005
ANGLES	± 2 DEGREES
FILLETS AND RADII	.001 - .005
HEX DIMENSIONS ARE:	
EXTERNAL	INTERNAL
≤ .5 +.000/- .003	≤ .5 +.003/- .000
> .5 +.000/- .005	> .5 +.005/- .000
INTERNAL THREAD DEPTH MIN. REMOVE ALL BURRS SHARP = R.000 - R.003	

DRAWN	CHECKED	ENGINEER
PST 8/8/25	JDM 8/8/25	NF 8/8/25

TITLE
APPROVAL EX(TO)(M)60X SERIES INTERCONNECTION

PCB PIEZOTRONICS
AN AMPHENOL COMPANY

3425 WALDEN AVE. DEPEW, NY 14043
(716)684-0002 E-MAIL: sales@pcb.com

CODE IDENT. NO. 52681	DWG. NO. 64371
SCALE: NONE	SHEET 1 OF 2

64371

PCB Piezotronics Inc. claims proprietary rights in the information disclosed hereon. Neither it nor any reproduction thereof will be disclosed to others without the written consent of PCB Piezotronics Inc.

SCHEDULE DRAWING
NO MODIFICATIONS PERMITTED WITHOUT REFERENCE TO THE NOTIFIED BODY

REVISIONS		
REV	DESCRIPTION	DIN
	-SEE SHEET 1-	

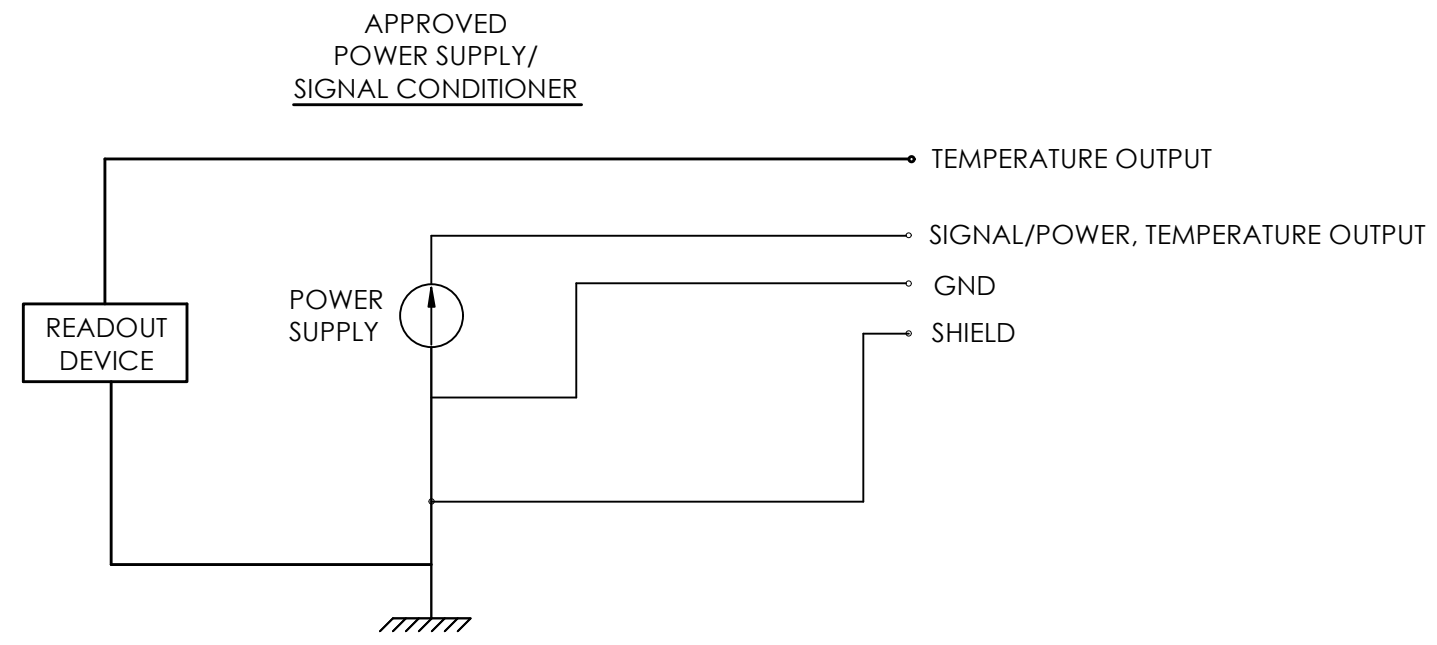

NON-HAZARDOUS / SAFE AREA
ZONE 2

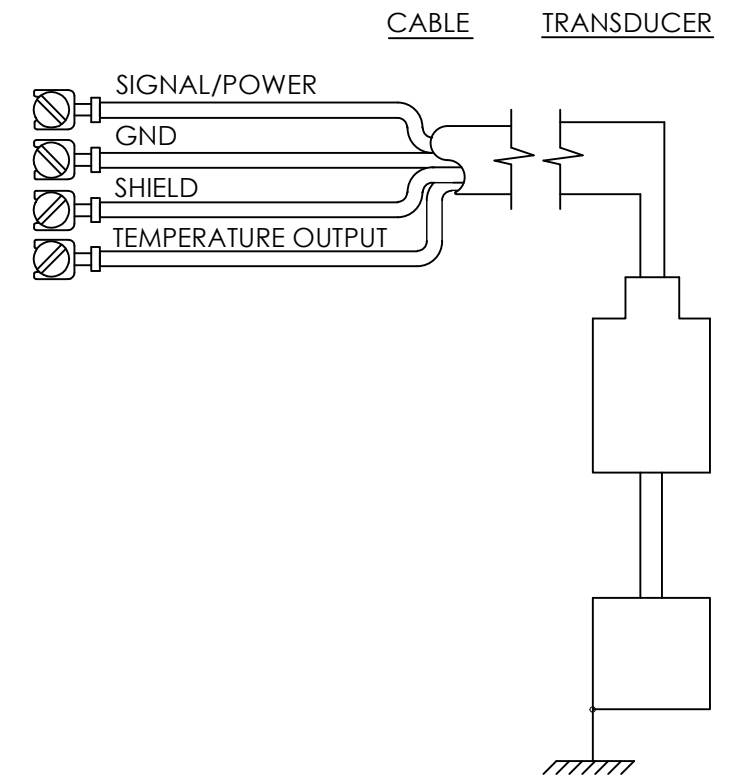

2.) MAXIMUM VOLTAGE OF POWER SUPPLY/SIGNAL CONDITIONER NEVER TO EXCEED 250 Vrms.

1.) CERTIFIED BY THE APPROPRIATE APPROVAL AUTHORITY FOR CONNECTION TO THE FOLLOWING AREAS:
ZONE 2
Exec nC IIC T4 Gc

NOTES: FOR MODELS INTEGRAL CABLE SERIES, Ci IS SPECIFIED AT A MAXIMUM CABLE LENGTH OF 500 FT. FOR SHORTER CABLE LENGTHS, Ci IS DECREASED BY 61 pF/FT.

UNLESS OTHERWISE SPECIFIED	
DIMENSIONS ARE IN INCHES	
DECIMALS	X ± .05
	XX ± .01
	XXX ± .005
	XXXX ± .0005
ANGLES	± 2 DEGREES
FILLETS AND RADII	.001 - .005
HEX DIMENSIONS ARE:	
EXTERNAL	INTERNAL
≤ .5 +.000/- .003	≤ .5 +.003/- .000
> .5 +.000/- .005	> .5 +.005/- .000
INTERNAL THREAD DEPTH MIN.	
REMOVE ALL BURRS	
SHARP = R.000 - R.003	

DRAWN	CHECKED	ENGINEER
PST 8/8/25	JDM 8/8/25	NF 8/8/25
TITLE		
APPROVAL EX(TO)(M)60X SERIES INTERCONNECTION		

PCB PIEZOTRONICS
AN AMPHENOL COMPANY

3425 WALDEN AVE. DEPEW, NY 14043
(716)684-0002 E-MAIL: sales@pcb.com

CODE IDENT. NO. 52681	DWG. NO. 64371
SCALE: NONE	SHEET 2 OF 2

EU-TYPE EXAMINATION

CERTIFICATE

Equipment or Protective System Intended for use in Potentially Explosive Atmospheres Directive 2014/34/EU

1. **EU-Type Examination Certificate Number:** ETL25ATEX0596X **Issue 1**
2. **Product:** Piezoelectric Vibration Sensor (EX602,603,606.607,608 SERIES* See Product Description)
3. **Manufacturer:** IMI Sensors a PCB Division
4. **Address:** 3425 Walden Ave, Depew, NY 14043, USA
Additional Manufacturer Thermometrics Mexico, S.A. DE
Address CAMINO VECINAL 15801, EDIFICIO 03 SUIT A COLONIA EL ROSARIO PARQUE INDUSTRIAL VESTA MEGA REGION; Tijuana, Mexico 22644
Additional Manufacturer PCB Piezotronics of North Carolina
Address 10869 HWy 903 Halifax, North Carolina 27839; USA
5. This product and any acceptable variation thereto is specified in the schedule to this certificate and the documents therein referred to.
6. Intertek Testing Services NA Ltd., Notified Body number 2903 in accordance with Article 17 of Directive 2014/34/EU of the European Parliament and of the Council dated 26 February 2014, certifies that the product has been found to comply with the Essential Health and Safety Requirements relating to the design and construction of products intended for use in potentially explosive atmospheres given in Annex II of the Directive.
7. Compliance with the Essential Health and Safety Requirements has been assured by compliance with EN IEC 60079-0:2018+A11:2024 and EN 60079-11:2012 except in respect of those requirements referred to within item 14 of the Schedule
8. If the sign "X" is placed after the certificate number, it indicates that the product is subject to the special conditions of use specified in the Schedule to this certificate.
9. This EU-Type Examination Certificate relates only to the design and construction of the specified product. Further requirements of the Directive apply to the manufacturing process and supply of this product. These are not covered by this certificate.
10. The marking of the product shall include the following:

II 1 G
 Ex ia IIC T4 Ga
 $-40^{\circ}\text{C} \leq T_a \leq +121^{\circ}\text{C}$

Certification Officer:

 Hope Alm

Date: 30 October 2025

SCHEDULE:

EU-Type Examination Certificate Number: ETL25ATEX0596X0 Issue 1

11. Description of Equipment or Protective System

The model EX602,603,606.607,608 SERIES is a series of vibration sensors integrating a piezoelectric crystal and electronic signal processing. These vibration sensors have four different main configurations:

1. 2-Wire (Conductors: + Signal/Power, - Signal/Common: 2-Conductors Total);
- 2. 2-Wire + Temperature Output (Conductors: + Signal/Power, Temperature Output, - Signal /Common: 3-Conductors Total);**
- 3. 3-Wire (Conductors: + Supply, Signal Output, -Supply/Common: 3-Conductors Total);**
- 4. 3-Wire + Temperature Output (Conductors: +Supply, Signal Output, Temperature Output, -Supply/Common: 4-Conductors Total).**

THESE ARE NEW

There are two (2) versions of external connection facilities:

1. connector or
2. an integrated cable

The delivered signal is an output reflecting vibration level, or vibration level and temperature output.

These products have two different installation methods and protection types for either:

1. **Zone 0: Ex ia using external barriers (THIS REPORT / CERTIFICATION)**
2. *Zone 2: Ex ec nC without external barriers (DIFFERENT REPORT / CERTIFICATION)*
 - *Ex ec (Non-Sparking) Applies to External and Internal Connections and Internal Circuits*
 - *Ex nC (Hermetically Sealed) Applies to the Internal Circuits of Connector Versions and to Piezo Element (Pellet)*

Model Nomenclature

EX may be followed by TO;
may be followed by M;
followed by 602, 603, 606, 607, 608;
followed by A to Z;
may be followed by 0 to 999;
may be followed by A to Z;
may be followed by /;
may be followed by M;
may be followed by 0 to 999;
may be followed by two characters.

Description:

EX (hazardous locations);
may be followed by M (Metric Thread for Mounting);
followed by 602, 603, 606, 607, 608 (series family of vibration sensors);
followed by A to Z (to denote model revision level);
may be followed by 0 to 999 for cable/connector type and sensitivity, filtering;
or bias (two numbers) or special order sequential number (up to three digits);
may be followed by /;
may be followed by M (Metric Cable Length);
may be followed by 0 to 999 (Cable Length or connector type);
may be followed by two characters (Cable Termination);
versions with 3 external conductors and not including "TO" in model code are 3-Wire;
versions with 4 external conductors, will include "TO" and are 3-Wire+TO

SCHEDULE:

EU-Type Examination Certificate Number: ETL25ATEX0596X0 Issue 1

12. Report Number

Intertek Report: 106274553CRT-006B (*G106248617) Dated: 29 October 2025

13. Special Conditions of Certification

- (a). Special Conditions of Use
 - All cabling shall be rated for a minimum ambient range of -40°C to +121°C.
- (b). Conditions of Manufacture - Routine Tests
 - None

14. Essential Health and Safety Requirements (EHSRs)

The relevant Essential Health and Safety Requirements (EHSRs) have been identified and assessed in Intertek Report: 106274553CRT-006B (*G106248617) Dated: 29 October 2025

15. Drawings and Documents

Title:	Drawing No.:	Rev. Level:	Date:
ATEX Technical File	33699	E	10/21/2025

16. Details of Certificate changes Issue 1

- ADD (TO = Temperature Output; 3-WIRE: Power, Output, GND) VERSIONS (FOR Ex ia: DUAL I.S BARRIERS VERSIONS)
- ADD (TO = Temperature Output + 3-WIRE: Power, Output, GND) VERSIONS (FOR Ex ia: TRIPLE I.S BARRIERS VERSIONS)

SIL Declaration of Conformity
Functional safety according to IEC 61508

Manufacturer: PCB Piezotronics
3425 Walden Avenue
Depew, NY 14043 USA

PCB Piezotronics declares as manufacturer, that the vibration transmitters:

- 602 Series (XX)602yzzz/aaa
- 603 Series (XX)603yzzz/aaa
- 606 Series (XX)606yzzz/aaa
- 607 Series (XX)607yzzz/aaa
- 608 Series (XX)608yzzz/aaa

(XX) Options include one or more of the following:

- EX – Approved for Hazardous Locations
- M – Metric Mounting Hardware
- TO – Dual Output (Vibration/Temperature)

Note: “yzzz” completes the model, “aaa” indicates cable length (if applicable)

Is hardware suitable for use in safety-instrumented systems according to IEC 61508, if the safety instructions and the following parameters are observed:

Parameter	60x Series*	EX60x Series*
SIL	2	2
Proof Test Interval (Annual)	8,760 h	8,760 h
Device Type	B	B
HFT	0	0
SFF	79.59%	79.59%
PFD _{AV} ¹	7.45 x 10 ⁻⁵	7.45 x 10 ⁻⁵
$\lambda_{du} \times 10^{-6}$	0.3348	0.3348
SIL Capability (Low Demand Mode)	2	2
SIL Capability (Continuous Demand Mode)	2	2
MTTF ²	9.5 y	9.5 y
1. The values comply with SIL2 according to ISA S84.01 2. According to Siemens SN29500 and Proven In Use data		

* With or without the M (metric) option

The PCB sensor hardware is suitable for inclusion in Safety Instrumented Systems (SIS) that are designed using IEC 61511 (for the process industry sector), IEC 62061 (safety of machinery), EN 50129 (railway applications), and ISO 26262 (automotive industry).

Note: The use of SIL Hardware in specific safety standard application may apply different number of sequences or definitions to those in IEC 61508.

July 2, 2019

PCB Piezotronics Authorized Representative:

Carrie Termin
Regulatory Affairs and Product Certification Specialist



PCB PIEZOTRONICS, INC. — CORPORATE HEADQUARTERS

3425 Walden Avenue, Depew, New York 14043-2495 USA

Phone: 716-684-0001 Fax: 716-684-0987

E-mail: info@pcb.com

Web site: www.pcb.com

AS9100 and ISO9001 Certified
ISO17025 Accredited

INTERTEK ASSURANCE SAFETY INTEGRITY LEVEL SUMMARY REPORT 60X PCB SIL SENSOR RATING

CLIENT NAME

PCB Piezotronics, Inc.
3425 Walden Ave
Depew, NY 14043-2417

REPORT NO

103685042CSLT-003

COMPILED BY

Ashton D. Hainge, CFSP, PMP

PROJECT NAME

G103685042

DATE

02 April 2019

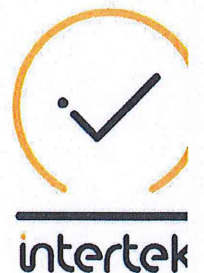
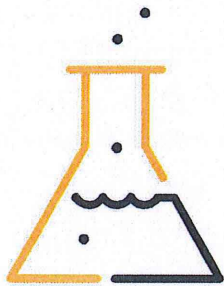
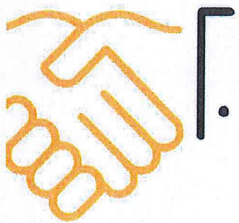



PCB FUNCTIONAL SAFETY SIL SUMMARY AND RESULTS

Summary

This report details the results of the reliability analysis performed on the PCB Piezotronics ICP Sensor model 60X series. Design changes from this documentation package would need to be evaluated for the impact on the reliability characteristics. These results are based on the following PCB Piezotronics documentation:

1. Electrical schematic 23402-NR
2. 603C01 MTTF Calculation
3. 602C11 – 602D11 MTTF Calculation
4. 607-608 MTTF Calculation
5. Manual of 603C01

Results

The results from the FMEA are given below for the ICP Sensor model 60X Series:

Name	Result
Architecture	1oo1
Proof test interval (Annual)	8,760 h
PFD _{avg}	7.45x10⁻⁵
SFF	79.59%
HFT	0
SIL Capability (Low Demand Mode)	2
SIL Capability (Continuous Demand Mode)	2
Architecture	1oo1

PCB Sensor Product Meets SIL 2 Capability



Name		Result
Safe Detected failure rate	$\lambda_{SD} \times 10^{-6}$	0.019
Safe Undetected failure rate	$\lambda_{SU} \times 10^{-6}$	0.013
Dangerous Detected failure rate	$\lambda_{DD} \times 10^{-6}$	0.033
Dangerous Undetected failure rate	$\lambda_{DU} \times 10^{-6}$	0.017
Average frequency of a dangerous failure on demand	PFH $\times 10^{-6}$	0.796

Type B components: 60X Series

The safety relevant parameter PFD_{avg} is in compliance with the corresponding requirements for SIL 2 according to IEC 61508¹. The safety relevant parameters HFT and SFF are in compliance with the corresponding requirements for SIL 1 according to IEC 61508. The user should consider, that the hardware fault tolerance of all inspected devices is zero and that a single fault can lead to a dangerous failure. Even though PFD_{avg} has the range of SIL 4, the hardware fault tolerance limits the capability to SIL 2.

Senior Consultant,

Ashton Hainge, Intertek
CFSP, PMP

¹ The assessment results described in this report only refer to the safety-related parameters PFD avg, HFT, and SFF according to IEC 61508.

This report does not make any statements, that the manufacturer meets all other requirements of the above cited standards for hardware, software, documentation, management of functional safety, verification, and validation.

This report does not imply that the examined pressure sensors have been certified for functional safety by the assessor according to IEC 61508 or any other standards.

The sensors are only one part of a complete safety function. It is at the responsibility of the end-user to prepare and to apply an extensive reliability model, that brings out the complete safety function and that meets all requirements of the claimed SIL level according to IEC 61508.

EU Declaration of Conformity PS060

In Accordance with ISO/IEC 17050

Manufacturer:
 PCB Piezotronics, Inc.
 3425 Walden Avenue
 Depew, New York 14043
 USA

Authorized European Representative:
 PCB Piezotronics GmbH
 Gut Gansbroich 1
 41836 Hückelhoven
 Germany

Certifies that type of equipment: ICP® Industrial Vibration Sensor(s)
Whose Product Models Include: EX(XX)602yzzz/aaa, EX(XX)603yzzz/aaa, EX(XX)606yzzzlaaa, EX(XX)607yzzz/aaa, EX(XX)608yzzz/aaaSeries

Note: "xx" is a place holder for two numbers.

For example: EX602D01Industrial Vibration Sensor
 These letters and numbers are included in the model numbers of the series.
 For details see the related data sheets.

This declaration is applicable to all ICP® Industrial Vibration Sensor(s) of the above series which have the ATEX mark on their data sheets and where those data sheets refer to this declaration of conformity. The data sheets for all model numbers referenced above, which include the ATEX mark on such data sheets and refer to this Declaration of Conformity are hereby incorporated by reference into this Declaration.

Conform to the following EU Directive(s) when installed per product documentation:	2014/30/EU	EMC Directive
	2014/34/EU	ATEX Directive
	2011/65/EU w/2015/863/EU	RoHS Directive

Harmonized Standards to which Conformity is Declared:

Harmonized Standards	EN 61326-1:2013	Electrical Equipment for Measurement, Control and Laboratory Use- EMC requirements - Part 1: General requirements
	EN 61326-2-3: 2013	Electrical equipment for measurement, control and laboratory use - EMC requirements - Part 2-3: Particular requirements - Test configuration, operational conditions and performance criteria for transducers with integrated or remote signal conditioning
	EN 61010-1:2010 EN 61010-1:2010/A1:2019/AC:2019-04 EN 61010-1:2010/A1:2019	Safety Requirements for Electrical Equipment for Measurement, Control, and Laboratory Use - Part 1: General Requirements
	EN IEC 60079-0:2018+A11:2024	Explosive Atmosphere - Part 0: Equipment - General requirements
	EN IEC 60079-7:2015+A1:2018	Explosive atmospheres - Part 7: Equipment protection by increased safety "e"
	EN 60079-11 2012	Explosive atmospheres - Part 11: Equipment protection by intrinsic safety "i"
	EN IEC 60079-15:2019	Explosive atmospheres - Part 15: Equipment protection by type of protection "n"
	EN IEC 63000:2018	Technical documentation for the assessment of electrical and electronic products with respect to the restriction of hazardous substances(IEC 63000:2018)
Emissions Test Standards	EN 55011:2016, EN 55011:2016/A1:2017 EN 55011:2016/A11:2020	Industrial, scientific and medical (ISM) radio frequency equipment-Electromagnetic disturbance characteristics- Limits and methods of Measurement Class B

Other Standards Applied (non-OJEU) Immunity Test Standards	EN 61000-4-2:2009 EN 61000-4-3:2006+A2:2010 EN 61000-4-4:2012 EN 61000-4-5:2014 EN 61000-4-6:2014 EN 61000-4-8:2010	Electromagnetic compatibility (EMC)–Part 4–2: Testing and measuring techniques– Electrostatic discharge immunity test Electromagnetic compatibility (EMC) - Part 4-3: Testing and measurement techniques - Radiated, radio-frequency, electromagnetic field immunity test Electromagnetic compatibility (EMC) - Part 4-4: Testing and measurement techniques - Electrical fast transient/burst immunity test Electromagnetic compatibility (EMC) - Part 4-5: Testing and measurement techniques - Surge immunity test Electromagnetic compatibility (EMC) - Part 4-6: Testing and measurement techniques - Immunity to conducted disturbances, induced by radio-frequency fields Electromagnetic compatibility (EMC) – Part 4-8: Testing and measurement techniques – Power frequency magnetic field immunity test
Test Reports	EMC Reports Safety Reports	GM29028c, GM29030c, GM29032c, GM29045c GM29029s, GM29031s, GM29033s, GM29046s
EC Type Examination	ATEX Certification EN IEC 60079-0:2018+A11:2024 EN 60079-11:2012	ETL25ATEX0596X Ex ia IIC T4, II 1G
Voluntary Certification	Voluntary Type Examination EN IEC 60079-0:2018+A11:2024 EN IEC 60079-7:2015+A1:2018 EN IEC 60079-15:2019	ETL25ATEX0595X Ex ec nC IIC T4 Gc
Other International Certifications	IECEX Certification IEC 60079-0:2017 (Edition:7.0) IEC 60079-7:2017 (Edition:5.1) IEC 60079-11:2011(Edition:6.0) IEC 60079-15:2017 (Edition:5.0)	IECEX ETL 25.0046X Ex ia IIC T4 Ga Ex ec nC IIC T4 Gc
Notified Body Name		Intertek Testing Services NA Ltd
Notified Body's Address		Intertek Testing Services NA Ltd 14920-135 Avenue Edmonton, AB, T5V 1R9, Canada Tel.: +1 780-440-4455

I, the undersigned, hereby declare that the equipment specified above conforms to the above Directive(s) Standard(s)

Place: Depew, NY Date: 11/24/2025

Signature: 

Name: Lance Pellens

Title: Director – Quality Assurance

UK Declaration of Conformity PS107UK

In Accordance with ISO/IEC 17050



Manufacturer:
PCB Piezotronics, Inc.
3425 Walden Avenue
Depew, New York 14043
USA

Authorized UK Representative:
PCB Piezotronics Ltd
Business and Technology Center
Bessemer Drive
Stevenage
Hertfordshire, SG1 2DX
United Kingdom

Certifies that type of equipment: ICP® Industrial Vibration Sensor(s)
Whose Product Models Include: EX(XX)602yzzz/aaa, EX(XX)603yzzz/aaa, EX(XX)606yzzzlaaa, EX(XX)607yzzz/aaa, EX(XX)608yzzz/aaa Series

Note: "xx" is a place holder for two numbers.

For example: EX602D01Industrial Vibration Sensor
These letters and numbers are included in the model numbers of the series.
For details see the related data sheets.

This declaration is applicable to all ICP® Industrial Vibration Sensor(s) of the above series which have the UKCA mark on their data sheets and where those data sheets refer to this declaration of conformity. The data sheets for all model numbers referenced above, which include the UKCA mark on such data sheets and refer to this Declaration of Conformity are hereby incorporated by reference into this Declaration.

Conform to the following UK Statutory Requirements when installed per product documentation: Electromagnetic Compatibility Regulations 2016 (SI 2016 No. 1091) Electrical Equipment (Safety) Regulations 2016
The Restriction of the Use of Certain Hazardous Substances in Electrical and Electronic Equipment Regulations 2012 (SI2012No3032 as Amended bySI2019 No696)

Designated Standards to which Conformity is Declared:

Designated Standards	BS EN 61326-1:2013	Electrical Equipment for Measurement, Control and Laboratory Use- EMC requirements - Part 1: General requirements
	BS EN 61326-2-3:2013	Electrical equipment for measurement, control and laboratory use - EMC requirements - Part 2-3: Particular requirements - Test configuration, operational conditions and performance criteria for transducers with integrated or remote signal conditioning
	BS EN 61010-1:2010 BS EN 61010-1:2010/A1:2019/AC:2019-04 BS EN 61010-1:2010/A1:2019	Safety requirements for electrical equipment for measurement, control, and laboratory use - Part 1: General requirements
	BS EN IEC 63000:2018	Technical documentation for the assessment of electrical and electronic products with respect to the restriction of hazardous substances (IEC 63000:2018)
Emissions Test Standards	BS EN 55011:2016, BS EN 55011:2016/A1:2017 BS EN 55011:2016/A11:2020	Industrial, scientific and medical (ISM) radio frequency equipment-Electromagnetic disturbance characteristics- Limits and methods of Measurement Class B

Other Standards Applied (non-OJEU) Immunity Test Standards	BS EN 61000-4-2:2009	Electromagnetic compatibility (EMC)–Part 4–2: Testing and measuring techniques– Electrostatic discharge immunity test
	BS EN 61000-4-3:2006+A2:2010	Electromagnetic compatibility (EMC) - Part 4-3: Testing and measurement techniques - Radiated, radio-frequency, electromagnetic field immunity test
	BS EN 61000-4-4:2012	Electromagnetic compatibility (EMC) - Part 4-4: Testing and measurement techniques - Electrical fast transient/burst immunity test
	BS EN 61000-4-5:2014	Electromagnetic compatibility (EMC) - Part 4-5: Testing and measurement techniques - Surge immunity test
	BS EN 61000-4-6:2014	Electromagnetic compatibility (EMC) - Part 4-6: Testing and measurement techniques - Immunity to conducted disturbances, induced by radio-frequency fields
	BS EN 61000-4-8:2010	Electromagnetic compatibility (EMC) – Part 4-8: Testing and measurement techniques – Power frequency magnetic field immunity test
Test Reports	EMC Reports Safety Reports	GM29028c, GM29030c, GM29034c, GM29045c GM29029s, GM29031s, GM29035s, GM29046s

I, the undersigned, hereby declare that the equipment specified above conforms to the above Directive(s) Standard(s)

Place: Depew, NY **Date:** 11/24/2025

Signature:



Name: Lance Pellens

Title: Director – Quality Assurance



IECEX Certificate of Conformity

INTERNATIONAL ELECTROTECHNICAL COMMISSION IEC Certification System for Explosive Atmospheres

for rules and details of the IECEx Scheme visit www.iecex.com

Certificate No.: **IECEX ETL 25.0046X** Page 1 of 4 [Certificate history:](#)
Issue 0 (2025-09-23)

Status: **Current** Issue No: 1

Date of Issue: 2025-10-30

Applicant: **PCB PIEZOTRONICS**
3425 Walden Avenue
Depew, New York, 1404
United States of America

Equipment: **Series of Vibration Sensors: EX602,603,606.607,608 SERIES* See Product Description**

Optional accessory:

Type of Protection: **Intrinsic Safety: Ex ia IIC T4 Ga; Increased Safety and Hermetically Sealed: Ex ec nC IIC T4 Gc**

Marking: **Ex ia IIC T4 Ga**
Ex ec nC IIC T4 Gc
IECEX ETL 25.0046X

Approved for issue on behalf of the IECEx
Certification Body:

Hope Alm

Position:

Certification Officer

Signature:
(for printed version)

Date:
(for printed version)

1. This certificate and schedule may only be reproduced in full.
2. This certificate is not transferable and remains the property of the issuing body.
3. The Status and authenticity of this certificate may be verified by visiting www.iecex.com or use of this QR Code.



Certificate issued by:

Intertek
3933 US Route 11 South
Cortland NY 13045-2995
United States of America

intertek



IECEX Certificate of Conformity

Certificate No.: **IECEX ETL 25.0046X**

Page 2 of 4

Date of issue: 2025-10-30

Issue No: 1

Manufacturer: **IMI Sensors a PCB Division**
3425 Walden Ave
Depew, NY 14043
United States of America

Manufacturing locations: **Thermometrics Mexico, S.A. DE** **PCB Piezotronics of North Carolina**
CAMINO VECINAL 15801, EDIFICIO **Inc**
03 SUIT A COLONIA EL ROSARIO 10869 Hwy 903
PARQUE INDUSTRIAL VESTA MEGA Halifax, NC 27839
REGION; **United States of America**
Tijuana 22644
Mexico

This certificate is issued as verification that a sample(s), representative of production, was assessed and tested and found to comply with the IEC Standard list below and that the manufacturer's quality system, relating to the Ex products covered by this certificate, was assessed and found to comply with the IECEx Quality system requirements. This certificate is granted subject to the conditions as set out in IECEx Scheme Rules, IECEx 02 and Operational Documents as amended

STANDARDS :

The equipment and any acceptable variations to it specified in the schedule of this certificate and the identified documents, was found to comply with the following standards

[IEC 60079-0:2017](#) Explosive atmospheres - Part 0: Equipment - General requirements
Edition:7.0

[IEC 60079-11:2011](#) Explosive atmospheres - Part 11: Equipment protection by intrinsic safety "i"
Edition:6.0

[IEC 60079-15:2017](#) Explosive atmospheres - Part 15: Equipment protection by type of protection "n"
Edition:5.0

[IEC 60079-7:2017](#) Explosive atmospheres - Part 7: Equipment protection by increased safety "e"
Edition:5.1

This Certificate **does not** indicate compliance with safety and performance requirements other than those expressly included in the Standards listed above.

TEST & ASSESSMENT REPORTS:

A sample(s) of the equipment listed has successfully met the examination and test requirements as recorded in:

Test Reports:

[US/ETL/ExTR25.0040/00](#)

[US/ETL/ExTR25.0040/01](#)

Quality Assessment Reports:

[NL/DEK/QAR14.0004/08](#)

[NL/DEK/QAR25.0004/00](#)



IECEX Certificate of Conformity

Certificate No.: **IECEX ETL 25.0046X**

Page 3 of 4

Date of issue: 2025-10-30

Issue No: 1

EQUIPMENT:

Equipment and systems covered by this Certificate are as follows:

The equipment is a series of vibration sensors integrating a piezoelectric crystal and electronic signal processing. These vibration sensors have four different main configurations:

1. 2-Wire (Conductors: + Signal/Power, - Signal/Common: 2-Conductors Total);
2. **2-Wire + Temperature Output (Conductors: + Signal/Power, Temperature Output, - Signal /Common: 3-Conductors Total);**
3. **3-Wire (Conductors: + Supply, Signal Output, -Supply/Common: 3-Conductors Total);**
4. **3-Wire + Temperature Output (Conductors: +Supply, Signal Output, Temperature Output, -Supply/Common: 4-Conductors Total).**
THESE ARE NEW

There are two (2) versions of external connection facilities:

1. connector or
2. an integrated cable

The delivered signal is an output reflecting vibration level, or vibration level and temperature output.

These products have two different installation methods and protection types for either:

1. Zone 0: Ex ia using external barriers
2. Zone 2: Ex ec nC without external barriers.
 - Ex ec (Non-Sparking) Applies to External and Internal Connections and Internal Circuits
 - Ex nC (Hermetically Sealed) Applies to the Internal Circuits of Connector Versions and to Piezo Element (Pellet)

Model Nomenclature

EX: may be followed by TO;

may be followed by M;

followed by 602, 603, 606, 607, 608;

followed by A to Z; may be followed by 0 to 999; may be followed by A to Z; may be followed by /; may be followed by M; may be followed by 0 to 999;

may be followed by two characters.

Description:

EX (hazardous locations);

- may be followed by TO (Temperature Output Option);

- may be followed by M (Metric Thread for Mounting);

- followed by 602, 603, 606, 607, 608 (series family of vibration sensors);

- followed by A to Z (to denote model revision level);

- may be followed by 0 to 999 for cable/connector type and sensitivity, filtering, or bias (two numbers) or special order sequential number (up to three digits);

- may be followed by /;

- may be followed by M (Metric Cable Length);

- may be followed by 0 to 999 (Cable Length or connector type);

- may be followed by two characters (Cable Termination).

- versions with 3 external conductors and not including "TO" in model code are 3-Wire

- versions with 4 external conductors, will include "TO" and are 3-Wire+TO

"In accordance with US government regulations, this Test Report cannot be used to support national certification in a country that is the subject of a comprehensive US trade embargo. For a list of countries subject to a comprehensive trade embargo, as well as a list of countries subject to more limited trade sanctions, see <https://home.treasury.gov/policy-issues/financial-sanctions/sanctions-programs-and-country-information>."

SPECIFIC CONDITIONS OF USE: YES as shown below:

1. All sealing devices including cable glands, blanking elements, thread adapters, stopping plugs and connectors shall be suitably certified when the equipment is installed in accordance with type of protection Ex ec. This connection shall maintain a minimum degree of protection of IP54 and have been submitted to all relevant type tests of IEC 60079-0. The sealing device shall have a rated service temperature in excess of -40°C to +121°C and be suitably sized for the cabling which is carried. Installation shall take into account any applicable special conditions for safe use or schedule of limitations and all relevant installation requirements of IEC 60079-14.

2. When the equipment is installed in accordance with method of protection Ex ec, the connection between the provided socket and installed plug must be made in a manner that cannot be separated without the use of a tool.

3. When the equipment is installed in accordance with type of protection Ex ec, the equipment shall be provided with transient protection which limits the input voltage to 39.2V (140% of the peak rated voltage value) at the supply terminals to the equipment.

4. All cabling shall be rated for a min ambient range of -40°C to +121°C.



IECEX Certificate of Conformity

Certificate No.: **IECEX ETL 25.0046X**

Page 4 of 4

Date of issue: 2025-10-30

Issue No: 1

DETAILS OF CERTIFICATE CHANGES (for issues 1 and above)

- ADD (TO = Temperature Output; 3-WIRE: Power, Output, GND) VERSIONS (FOR Ex ia: DUAL I.S BARRIERS VERSIONS)
- ADD (TO = Temperature Output + 3-WIRE: Power, Output, GND) VERSIONS (FOR Ex ia: TRIPLE I.S BARRIERS VERSIONS)
- Delete Special Condition: "Integral cable version is limited to Ex ic version of equipment. The maximum cable length specified is 327'."

Annex:

[Annex to IECEx C of C - Cortland_1.pdf](#)



Annex to IECEx Certificate of Conformity

Certificate No:	IECEX ETL 25.0046X	Issue No. 1
Annex No. 1		

Technical Documents			
Title:	Drawing No.:	Rev. Level:	Date:
*TECHNICAL FILE INTRINSICALLY SAFE and NON- SPARKING IECEX Ex ia and Ex nA	56178	D	10/20/2025

*Note: An * is included before the title of documents that are new or revised.*

Certificate issued by:

intertek
Total Quality. Assured.

Intertek Testing Services NA, Inc.
3933 Route 11
Cortland, NY 13045, USA

Page 1 of 3

SFT-IECEX-OP-19f
(16 January 2025)



Annex to IECEx Certificate of Conformity

Certificate No:	IECEX ETL 25.0046X	Issue No. 1
Annex No. 1		

Required Manufacturer Routine Testing		
Test	Title/Description of Test	Standard and Clause
1	IEC 60079-7: 2017 Clause 7.1 & IEC 60079-15: 2017 Clause 12.1 – A dielectric strength test shall be carried out at 500V r.m.s for 60 seconds. Alternatively, a test shall be carried out at 1.2 times the test voltage but maintained for at least 100 ms.	IEC 60079-7:2017 Clause 7.1 IEC 60079-15:2017 Clause 12.1

Certificate issued by:

intertek

Total Quality. Assured.

Intertek Testing Services NA, Inc.
3933 Route 11
Cortland, NY 13045, USA

Page 2 of 3

SFT-IECEX-OP-19f
(16 January 2025)



Annex to IECEx Certificate of Conformity

Certificate No:	IECEX ETL 25.0046X	Issue No. 1
Annex No. 1		

Ratings

(Zone 0: Ex ia):

Single Barrier (Channel) Versions:

Ui = 28V, li = 93mA, Pi = 0.65W,

- Model with connector: Ci = 46.5nF, Li = 0;
- Models with cables up to 500 feet: Ci = 77nF, Li = 152.5μH;

Temperature Output Option 1: Dual Barriers (Channels) Versions:

POWER: Ui = 28V, li = 93mA, Pi = 0.65W,

- Model with connector: Ci = 46.5nF, Li = 0;
- Models with cables up to 500 feet: Ci = 77nF, Li = 152.5μH;

TO: Ui = 28V, li = 27mA, Pi = 0.65W

- Model with connector: Ci = 46.5nF, Li = 0;
- Models with cables up to 500 feet: Ci = 77nF, Li = 152.5μH;

Temperature Output Option 2: Dual Barriers (Channels) Added Versions:

POWER + TO: Ui = 28V, li = 120mA (TOTAL OF BOTH CHANNELS), Pi = 0.65W,

- Model with connector: Ci = 46.5nF, Li = 0;
- Models with cables up to 500 feet: Ci = 77nF, Li = 152.5μH;

Three Wire Option: Dual Barriers (Channels) Versions:

POWER: Ui = 8V, li = 160mA, Pi = 0.65W,

- Model with connector: Ci = 24.6nF, Li = 0;
- Models with cables up to 328 feet: Ci = 44.6nF, Li = 152.5μH;

VOU: Ui = 8V, li = 160mA, Pi = 0.65W,

- Model with connector: Ci = 24.6nF, Li = 0;
- Models with cables up to 328 feet: Ci = 44.6nF, Li = 152.5μH;

Temperature Output + Three Wire Option: Triple Barrier (Channel) Versions:

POWER: Ui = 8V, li = 160mA, Pi = 0.65W,

- Model with connector: Ci = 24.6nF, Li = 0;
- Models with cables up to 328 feet: Ci = 44.6nF, Li = 152.5μH;

VOU: Ui = 8V, li = 160mA, Pi = 0.65W,

- Model with connector: Ci = 24.6nF, Li = 0;
- Models with cables up to 328 feet: Ci = 44.6nF, Li = 152.5μH;

TO: Ui = 8V, li = 160mA, Pi = 0.65W,

- Model with connector: Ci = 24.6, Li = 0;
- Models with cables up to 328 feet: Ci = 44.6nF, Li = 152.5μH;

(Zone 2: Ex ec nC):

- 30V, 100mA

Certificate issued by:



Total Quality. Assured.

Intertek Testing Services NA, Inc.
3933 Route 11
Cortland, NY 13045, USA

Page 3 of 3

SFT-IECEX-OP-19f
(16 January 2025)

This authorizes the application of the Certification Mark(s) shown below to the models described in the Product(s) Covered section when made in accordance with the conditions set forth in the Certification Agreement and Listing Report. This authorization also applies to multiple listee model(s) identified on the correlation page of the Listing Report.

This document is the property of Intertek Testing Services and is not transferable. The certification mark(s) may be applied only at the location of the Party Authorized To Apply Mark.

Applicant: PCB Piezotronics Inc.

Manufacturer: PCB Piezotronics Inc.

Address: 3425 Walden Ave Depew, NY 14043-2417

Address: 3425 Walden Ave Depew, NY 14043-2417

Country: USA

Country: USA

Party Authorized To Apply Mark: Same as Manufacturer
Report Issuing Office: Intertek Testing Services NA, Inc., Cortland, NY

Control Number: 5010230

Authorized by: Chardlen Jarboe
for L. Matthew Snyder, Certification Manager



This document supersedes all previous Authorizations to Mark for the noted Report Number.

This Authorization to Mark is for the exclusive use of Intertek's Client and is provided pursuant to the Certification agreement between Intertek and its Client. Intertek's responsibility and liability are limited to the terms and conditions of the agreement. Intertek assumes no liability to any party, other than to the Client in accordance with the agreement, for any loss, expense or damage occasioned by the use of this Authorization to Mark. Only the Client is authorized to permit copying or distribution of this Authorization to Mark and then only in its entirety. Use of Intertek's Certification mark is restricted to the conditions laid out in the agreement and in this Authorization to Mark. Any further use of the Intertek name for the sale or advertisement of the tested material, product or service must first be approved in writing by Intertek. Initial Factory Assessments and Follow up Services are for the purpose of assuring appropriate usage of the Certification mark in accordance with the agreement, they are not for the purposes of production quality control and do not relieve the Client of their obligations in this respect.

Intertek Testing Services NA Inc.
545 East Algonquin Road, Arlington Heights, IL 60005
Telephone 800-345-3851 or 847-439-5667 Fax 312-283-1672

Intrinsically Safe Apparatus and Associated Apparatus for Use in Class I, II, and III, Division 1, Hazardous (Classified) Locations [UL 913:2013 Ed.8+R:10May2022]

Explosive Atmospheres – Part 0: Equipment – General Requirements [UL 60079-0:2019 Ed.7+R:19Jul2024]

Explosive Atmospheres - Part 11: Equipment Protection by Intrinsic Safety "i" [UL 60079-11:2013 Ed.6+R:25Jan2023]

Standard for Safety Explosive Atmospheres - Part 7: Equipment Protection by Increased Safety "e" [UL 60079-7:2017 Ed.5+R:03Jun2021]

Explosive Atmospheres - Part 15: Equipment Protection by Type of Protection 'N' [UL 60079-15:2020 Ed.5+R:27Jun2024]

Standard(s): Explosive Atmospheres - Part 0: Equipment - General Requirements (R2024) [CSA C22.2#60079-0:2019]

	<p>Standard(s): Ed.4]</p> <p>Explosive Atmospheres - Part 11: Equipment Protection by Intrinsic Safety "i" (R2023) [CSA C22.2#60079-11:2014 Ed.2]</p> <p>Explosive Atmospheres - Part 7: Equipment Protection by Increased Safety "e" (R2021) [CSA C22.2#60079-7:2016 Ed.2+A1]</p> <p>Explosive Atmospheres - Part 15: Equipment Protection by Type of Protection "n" [CSA C22.2#60079-15:2018 Ed.3]</p> <p>Electrical Equipment for Measurement, Control, and Laboratory Use; Part 1: General Requirements [UL 61010-1:2012 Ed.3+R:15Nov2024]</p> <p>Safety Requirements for Electrical Equipment for Measurement, Control, and Laboratory Use Part 1: General Requirements [CSA C22.2#61010-1-12:2012 Ed.3+U1;U2;A1;U3;U4]</p>
<p>Product:</p>	<p>Vibration Transmitters For use in:</p> <ul style="list-style-type: none"> - Class I, Division 1, Groups A – D (Ex ia) - Class II, Division 1, Groups E – G - Class III, Division 1 - Class I, Zone 0, AEx ia IIC T4 Ga - Ex ia IIC T4 Ga - Class I, Zone 2, AEx ec nC T4 Gc - Ex ec nC T4 Gc - Class I, Division 2, Groups A – D (Ex ec nC) <p>Temperature Class: T4 Ambient Temperature Range: -54°C ≤ Tamb ≤ +121°C</p>
<p>Brand Name:</p>	<p>IMI Sensors a Division of PCB Piezotronics</p>
<p>Models:</p>	<p>EX may be followed by TO; may be followed by M; followed by 602, 603, 606, 607, 608; followed by A to Z; may be followed by 0 to 999; may be followed by A to Z; may be followed by /; may be followed by M; may be followed by 0 to 999; may be followed by two characters.</p>

This authorizes the application of the Certification Mark(s) shown below to the models described in the Product(s) Covered section when made in accordance with the conditions set forth in the Certification Agreement and Listing Report. This authorization also applies to multiple listee model(s) identified on the correlation page of the Listing Report.

This document is the property of Intertek Testing Services and is not transferable. The certification mark(s) may be applied only at the location of the Party Authorized To Apply Mark.

Applicant:	PCB Piezotronics Inc.	Manufacturer:	Thermometrics Mexico, S.A. DE C.V.
			CAMINO VECINAL 15801, EDIFICIO 03
			SUIT A COLONIA EL ROSARIO
Address:	3425 Walden Ave Depew, NY 14043-2417	Address:	PARQUE INDUSTRIAL VESTA MEGA REGION;
			Tijuana, Mexico 22644
Country:	USA	Country:	Mexico
Party Authorized To Apply Mark:	Same as Manufacturer		
Report Issuing Office:	Intertek Testing Services NA, Inc., Cortland, NY		
Control Number:	<u>5034416</u>	Authorized by:	<u><i>Chardler Jarboe</i></u> for L. Matthew Snyder, Certification Manager



This document supersedes all previous Authorizations to Mark for the noted Report Number.

This Authorization to Mark is for the exclusive use of Intertek's Client and is provided pursuant to the Certification agreement between Intertek and its Client. Intertek's responsibility and liability are limited to the terms and conditions of the agreement. Intertek assumes no liability to any party, other than to the Client in accordance with the agreement, for any loss, expense or damage occasioned by the use of this Authorization to Mark. Only the Client is authorized to permit copying or distribution of this Authorization to Mark and then only in its entirety. Use of Intertek's Certification mark is restricted to the conditions laid out in the agreement and in this Authorization to Mark. Any further use of the Intertek name for the sale or advertisement of the tested material, product or service must first be approved in writing by Intertek. Initial Factory Assessments and Follow up Services are for the purpose of assuring appropriate usage of the Certification mark in accordance with the agreement, they are not for the purposes of production quality control and do not relieve the Client of their obligations in this respect.

Intertek Testing Services NA Inc.
545 East Algonquin Road, Arlington Heights, IL 60005
Telephone 800-345-3851 or 847-439-5667 Fax 312-283-1672

Intrinsically Safe Apparatus and Associated Apparatus for Use in Class I, II, and III, Division 1, Hazardous (Classified) Locations [UL 913:2013 Ed.8+R:10May2022]
Explosive Atmospheres – Part 0: Equipment – General Requirements [UL 60079-0:2019 Ed.7+R:19Jul2024]
Explosive Atmospheres - Part 11: Equipment Protection by Intrinsic Safety "i" [UL 60079-11:2013 Ed.6+R:25Jan2023]
Standard for Safety Explosive Atmospheres - Part 7: Equipment Protection by Increased Safety "e" [UL 60079-7:2017 Ed.5+R:03Jun2021]
Explosive Atmospheres - Part 15: Equipment Protection by Type of Protection 'N' [UL 60079-15:2020 Ed.5+R:27Jun2024]
Standard(s): Explosive Atmospheres - Part 0: Equipment - General Requirements (R2024) [CSA C22.2#60079-0:2019]

	<p>Standard(s): Ed.4]</p> <p>Explosive Atmospheres - Part 11: Equipment Protection by Intrinsic Safety "i" (R2023) [CSA C22.2#60079-11:2014 Ed.2]</p> <p>Explosive Atmospheres - Part 7: Equipment Protection by Increased Safety "e" (R2021) [CSA C22.2#60079-7:2016 Ed.2+A1]</p> <p>Explosive Atmospheres - Part 15: Equipment Protection by Type of Protection "n" [CSA C22.2#60079-15:2018 Ed.3]</p> <p>Electrical Equipment for Measurement, Control, and Laboratory Use; Part 1: General Requirements [UL 61010-1:2012 Ed.3+R:15Nov2024]</p> <p>Safety Requirements for Electrical Equipment for Measurement, Control, and Laboratory Use Part 1: General Requirements [CSA C22.2#61010-1-12:2012 Ed.3+U1;U2;A1;U3;U4]</p>
<p>Product:</p>	<p>Vibration Transmitters For use in:</p> <ul style="list-style-type: none"> - Class I, Division 1, Groups A – D (Ex ia) - Class II, Division 1, Groups E – G - Class III, Division 1 - Class I, Zone 0, AEx ia IIC T4 Ga - Ex ia IIC T4 Ga - Class I, Zone 2, AEx ec nC T4 Gc - Ex ec nC T4 Gc - Class I, Division 2, Groups A – D (Ex ec nC) <p>Temperature Class: T4 Ambient Temperature Range: -54°C ≤ Tamb ≤ +121°C</p>
<p>Brand Name:</p>	<p>IMI Sensors a Division of PCB Piezotronics</p>
<p>Models:</p>	<p>EX may be followed by TO; may be followed by M; followed by 602, 603, 606, 607, 608; followed by A to Z; may be followed by 0 to 999; may be followed by A to Z; may be followed by /; may be followed by M; may be followed by 0 to 999; may be followed by two characters.</p>

This authorizes the application of the Certification Mark(s) shown below to the models described in the Product(s) Covered section when made in accordance with the conditions set forth in the Certification Agreement and Listing Report. This authorization also applies to multiple listee model(s) identified on the correlation page of the Listing Report.

This document is the property of Intertek Testing Services and is not transferable. The certification mark(s) may be applied only at the location of the Party Authorized To Apply Mark.

UNOFFICIAL

Applicant: PCB Piezotronics Inc. **Manufacturer:** PCB Piezotronics of North Carolina Inc

Address: 3425 Walden Ave Depew, NY 14043-2417 **Address:** 10869 HWy 903 Halifax, North Carolina 27839

Country: USA **Country:** USA

Party Authorized To Apply Mark: Same as Manufacturer
Report Issuing Office: Intertek Testing Services NA, Inc., Cortland, NY

Control Number: 5034913 **Authorized by:** Pending IFA
for L. Matthew Snyder, Certification Manager



This document supersedes all previous Authorizations to Mark for the noted Report Number.

This Authorization to Mark is for the exclusive use of Intertek's Client and is provided pursuant to the Certification agreement between Intertek and its Client. Intertek's responsibility and liability are limited to the terms and conditions of the agreement. Intertek assumes no liability to any party, other than to the Client in accordance with the agreement, for any loss, expense or damage occasioned by the use of this Authorization to Mark. Only the Client is authorized to permit copying or distribution of this Authorization to Mark and then only in its entirety. Use of Intertek's Certification mark is restricted to the conditions laid out in the agreement and in this Authorization to Mark. Any further use of the Intertek name for the sale or advertisement of the tested material, product or service must first be approved in writing by Intertek. Initial Factory Assessments and Follow up Services are for the purpose of assuring appropriate usage of the Certification mark in accordance with the agreement, they are not for the purposes of production quality control and do not relieve the Client of their obligations in this respect.

Intertek Testing Services NA Inc.
545 East Algonquin Road, Arlington Heights, IL 60005
Telephone 800-345-3851 or 847-439-5667 Fax 312-283-1672

DATED

Intrinsically Safe Apparatus and Associated Apparatus for Use in Class I, II, and III, Division 1, Hazardous (Classified) Locations [UL 913:2013 Ed.8+R:10May2022]

Explosive Atmospheres – Part 0: Equipment – General Requirements [UL 60079-0:2019 Ed.7+R:19Jul2024]

Explosive Atmospheres - Part 11: Equipment Protection by Intrinsic Safety "i" [UL 60079-11:2013 Ed.6+R:25Jan2023]

Standard for Safety Explosive Atmospheres - Part 7: Equipment Protection by Increased Safety "e" [UL 60079-7:2017 Ed.5+R:03Jun2021]

Explosive Atmospheres - Part 15: Equipment Protection by Type of Protection 'N' [UL 60079-15:2020 Ed.5+R:27Jun2024]

Standard(s): Explosive Atmospheres - Part 0: Equipment - General Requirements (R2024) [CSA C22.2#60079-0:2019]

Standard(s):	Ed.4] Explosive Atmospheres - Part 11: Equipment Protection by Intrinsic Safety "i" (R2023) [CSA C22.2#60079-11:2014 Ed.2] Explosive Atmospheres - Part 7: Equipment Protection by Increased Safety "e" (R2021) [CSA C22.2#60079-7:2016 Ed.2+A1] Explosive Atmospheres - Part 15: Equipment Protection by Type of Protection "n" [CSA C22.2#60079-15:2018 Ed.3] Electrical Equipment for Measurement, Control, and Laboratory Use; Part 1: General Requirements [UL 61010-1:2012 Ed.3+R:15Nov2024] Safety Requirements for Electrical Equipment for Measurement, Control, and Laboratory Use Part 1: General Requirements [CSA C22.2#61010-1-12:2012 Ed.3+U1;U2;A1;U3;U4]
Product:	Vibration Transmitters For use in: - Class I, Division 1, Groups A – D (Ex ia) - Class II, Division 1, Groups E – G - Class III, Division 1 - Class I, Zone 0, AEx ia IIC T4 Ga - Ex ia IIC T4 Ga - Class I, Zone 2, AEx ec nC T4 Gc - Ex ec nC T4 Gc - Class I, Division 2, Groups A – D (Ex ec nC) Temperature Class: T4 Ambient Temperature Range: -54°C ≤ Tamb ≤ +121°C
Brand Name:	IMI Sensors a Division of PCB Piezotronics
Models:	EX may be followed by TO; may be followed by M; followed by 602, 603, 606, 607, 608; followed by A to Z; may be followed by 0 to 999; may be followed by A to Z; may be followed by /; may be followed by M; may be followed by 0 to 999; may be followed by two characters.

TYPE EXAMINATION CERTIFICATE

Equipment or Protective System Intended for use in Potentially Explosive Atmospheres Directive 2014/34/EU

1. **Type Examination Certificate Number:** ETL25ATEX0595X **Issue 1**
2. **Product:** Piezoelectric Vibration Sensor (EX602,603,606.607,608 SERIES* See Product Description)
3. **Manufacturer:** IMI Sensors a PCB Division
4. **Address:** 3425 Walden Ave, Depew, NY 14043, USA
Additional Manufacturer Thermometrics Mexico, S.A. DE
Address CAMINO VECINAL 15801, EDIFICIO 03 SUIT A COLONIA EL ROSARIO PARQUE INDUSTRIAL VESTA MEGA REGION; Tijuana, Mexico 22644
Additional Manufacturer PCB Piezotronics of North Carolina
Address 10869 HWy 903 Halifax, North Carolina 27839; USA
5. This product and any acceptable variation thereto is specified in the schedule to this certificate and the documents therein referred to.
6. Intertek Testing Services NA Ltd., certifies that this product has been found to comply with the Essential Health and Safety Requirements relating to the design and construction of the products intended for use in potentially explosive atmospheres given in Annex II of Directive 2014/34/EU of the European Parliament and of the Council, dated 26 February 2014.
7. Compliance with the Essential Health and Safety Requirements has been assured by compliance with EN IEC 60079-0:2018+A11:2024, EN IEC 60079-7:2015+A1:2018 and EN IEC 60079-15:2019 except in respect of those requirements referred to within item 14 of the Schedule
8. If the sign "X" is placed after the certificate number, it indicates that the product is subject to the special conditions of use specified in the Schedule to this certificate.
9. This Type Examination Certificate relates only to the design of the specified product and not to specific items subsequently manufactured.
10. The marking of the product shall include the following:

II 3 G
 Ex ec nC IIC T4 Gc
 $-40^{\circ}\text{C} \leq T_a \leq +121^{\circ}\text{C}$

**Certification
Officer:**

Hope Alm

Date: 30 October 2025

SCHEDULE:

TYPE EXAMINATION CERTIFICATE NUMBER ETL25ATEX0595X Issue 01

11. Description of Equipment or Protective System

The model EX602,603,606.607,608 SERIES is a series of vibration sensors integrating a piezoelectric crystal and electronic signal processing. These vibration sensors have four different main configurations:

1. 2-Wire (Conductors: + Signal/Power, - Signal/Common: 2-Conductors Total);
- 2. 2-Wire + Temperature Output (Conductors: + Signal/Power, Temperature Output, - Signal /Common: 3-Conductors Total);**
- 3. 3-Wire (Conductors: + Supply, Signal Output, -Supply/Common: 3-Conductors Total);**
- 4. 3-Wire + Temperature Output (Conductors: +Supply, Signal Output, Temperature Output, -Supply/Common: 4-Conductors Total).**

THESE ARE NEW

There are two (2) versions of external connection facilities:

1. connector or
2. an integrated cable

The delivered signal is an output reflecting vibration level, or vibration level and temperature output.

These products have two different installation methods and protection types for either:

1. *Zone 0: Ex ia using external barriers (DIFFERENT REPORT / CERTIFICATION)*
2. **Zone 2: Ex ec nC without external barriers (THIS REPORT / CERTIFICATION)**
 - **Ex ec (Non-Sparking) Applies to External and Internal Connections and Internal Circuits**
 - **Ex nC (Hermetically Sealed) Applies to the Internal Circuits of Connector Versions and to Piezo Element (Pellet)**

Model Nomenclature

EX

may be followed by TO;
 may be followed by M;
 followed by 602, 603, 606, 607, 608;
 followed by A to Z;
 may be followed by 0 to 999;
 may be followed by A to Z;
 may be followed by /;
 may be followed by M;
 may be followed by 0 to 999;
 may be followed by two characters.

Description:

EX (hazardous locations);
 may be followed by M (Metric Thread for Mounting);
 followed by 602, 603, 606, 607, 608 (series family of vibration sensors);
 followed by A to Z (to denote model revision level);
 may be followed by 0 to 999 for cable/connector type and sensitivity, filtering;
 or bias (two numbers) or special order sequential number (up to three digits);
 may be followed by /;
 may be followed by M (Metric Cable Length);
 may be followed by 0 to 999 (Cable Length or connector type);
 may be followed by two characters (Cable Termination);
 versions with 3 external conductors and not including "TO" in model code are 3-Wire;
 versions with 4 external conductors, will include "TO" and are 3-Wire+TO

SCHEDULE:

TYPE EXAMINATION CERTIFICATE NUMBER ETL25ATEX0595X Issue 01

12. Report Number

Intertek Report: 106274553CRT-005B Dated: 29 October 2025

13. Conditions of Certification

(a). Special Conditions of Use

- All sealing devices including cable glands, blanking elements, thread adapters, stopping plugs and connectors shall be suitably certified when the equipment is installed in accordance with type of protection Ex ec. This connection shall maintain a minimum degree of protection of IP54 and have been submitted to all relevant type tests of EN IEC 60079-0. The sealing device shall have a rated service temperature in excess of -40°C to +121°C and be suitably sized for the cabling which is carried. Installation shall take into account any applicable special conditions for safe use or schedule of limitations and all relevant installation requirements of EN 60079-14.
- When the equipment is installed in accordance with method of protection Ex ec, the connection between the provided socket and installed plug must be made in a manner that cannot be separated without the use of a tool.
- When the equipment is installed in accordance with type of protection Ex ec, the equipment shall be provided with transient protection which limits the input voltage to 39.2V (140% of the peak rated voltage value) at the supply terminals to the equipment.
- All cabling shall be rated for a minimum ambient range of -40°C to +121°C.

(b). Conditions of Manufacture - Routine Tests

- EN IEC 60079-7:2015+A1:2018 Clause 7.1 & EN IEC 60079-15:2019 Clause 12.1 – A dielectric strength test shall be carried out at 500V r.m.s for 60 seconds. Alternatively, a test shall be carried out at 1.2 times the test voltage but maintained for at least 100 ms.

14. Essential Health and Safety Requirements (EHSRs)

The relevant Essential Health and Safety Requirements (EHSRs) affected by this variation have been identified and assessed in Intertek report 106274553CRT-005B Dated: 29 October 2025

15. Drawings and Documents

Title:	Drawing No.:	Rev. Level:	Date:
ATEX Technical File	33699	E	10/21/2025

16. Details of Certificate changes Issue 1

- ADD (TO = Temperature Output; 3-WIRE: Power, Output, GND) VERSIONS (FOR Ex ia: DUAL I.S BARRIERS VERSIONS)
- ADD (TO = Temperature Output + 3-WIRE: Power, Output, GND) VERSIONS (FOR Ex ia: TRIPLE I.S BARRIERS VERSIONS)
- Delete Special Condition: "Integral cable version is limited to Ex ic version of equipment. The maximum cable length specified is 327'."